

USPAS Accelerator Physics 2021 (Virtually) Texas A&M University

Chapter 6+: Magnets

Todd Satogata (Jefferson Lab and ODU) / satogata@jlab.org

Steve Peggs (BNL) / peggs@bnl.gov

Daniel Marx (BNL) / dmarx@bnl.gov and Nilanjan Banerjee / nb522@cornell.edu

<http://www.toddsatogata.net/2021-USPAS>

Username test / Password test

Overview

- Back to Maxwell
 - Parameterizing fields in accelerator magnets
 - Symmetries, comments about magnet construction
- Relating currents and fields
 - Equipotentials and contours, dipoles and quadrupoles
 - Thin magnet kicks and that ubiquitous rigidity
 - Complications: hysteresis, end fields
- More details about dipoles
 - Sector and rectangular bends; edge focusing
- Extras: Superconducting magnets
 - RHIC, LHC, the future

Other References

- Magnet design and a construction is a specialized field all its own
 - Electric, Magnetic, Electromagnetic modeling
 - 2D, 3D, static vs dynamic
 - Materials science
 - Conductors, superconductors, ferrites, superferrites
 - Measurements and mapping
 - e.g. g-2 experiment: 1 PPM field uniformity, 14m SC dipole
- Entire USPAS courses have been given on just superconducting magnet design
 - <http://www.bnl.gov/magnets/staff/gupta/scmag-course/>
(Ramesh Gupta and Animesh Jain, BNL)

g-2 magnet

At Brookhaven

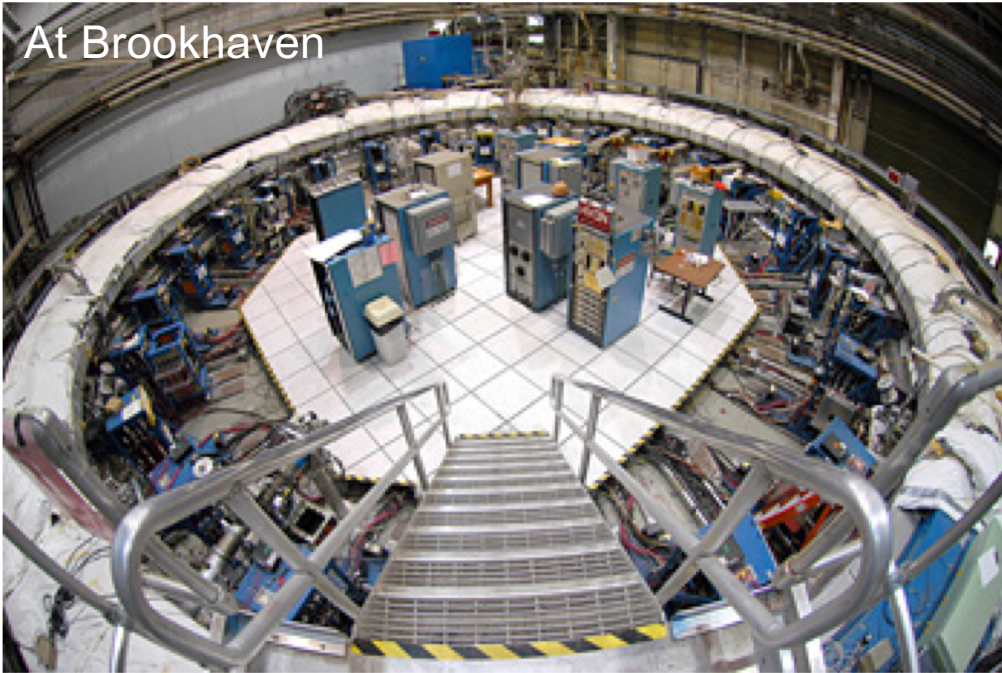

- Magnet moved from Brookhaven to Fermilab in 2013
 - 17 tons, 44m circumference, 18 cm gap
 - 35 days, over 3200 miles
 - <http://muon-g-2.fnal.gov/bigmove/>

On the move



At Fermilab



EM/Maxwell Review I

- Recall our relativistic Lorentz force

$$\frac{d(\gamma m \vec{v})}{dt} = q \left(\vec{E} + \vec{v} \times \vec{B} \right)$$

- For large γ common in accelerators, transverse magnetic fields are **much** more effective for changing particle momenta
- Can mostly separate E (RF, septa) and B (DC magnets)
 - Some exceptions, e.g. plasma wakefields, betatrons, RFQ
- Easiest/simplest: magnets with constant B field
 - Constant-strength optics
 - Most varying B field accelerator magnets change field so slowly that E fields are negligible
 - Consistent with our constant-field assumptions

EM/Maxwell Review II

- Maxwell's Equations for \vec{B} , \vec{H} and magnetization \vec{M} are

$$\vec{\nabla} \cdot \vec{B} = 0 \quad \vec{\nabla} \times \vec{H} = \vec{j} + \epsilon_0 \frac{\partial \vec{E}}{\partial t} = \vec{j} \quad \vec{H} \equiv \vec{B}/\mu - \vec{M}$$

- A magnetic vector potential \vec{A} exists

$$\vec{B} = \vec{\nabla} \times \vec{A} \quad \text{since } \vec{\nabla} \cdot \vec{\nabla} \times \vec{A} = 0$$

- Transverse 2D ($B_z=H_z=0$), paraxial approx ($p_{x,y} \ll p_0$)
- Away from magnet coils ($\vec{j} = 0$, $\vec{M} = 0$)
 - Simple homogeneous differential equations for fields

$$\frac{\partial B_x}{\partial x} + \frac{\partial B_y}{\partial y} = 0 \quad \frac{\partial B_x}{\partial y} - \frac{\partial B_y}{\partial x} = 0$$

Parameterizing Solutions

$$\frac{\partial B_x}{\partial x} + \frac{\partial B_y}{\partial y} = 0 \quad \frac{\partial B_x}{\partial y} - \frac{\partial B_y}{\partial x} = 0$$

- What are solutions to these equations?
 - Constant field: $\vec{B} = B_x x^0 \hat{x} + B_y y^0 \hat{y}$
 - Dipole fields, usually either only B_x or B_y
 - 360 degree (2π) rotational “symmetry”
 - First order field: $\vec{B} = (B_{xx}x + B_{xy}y)\hat{x} + (B_{yx}x + B_{yy}y)\hat{y}$
 - Maxwell reduces 4 vars to 2: $B_s = B_{xx} = -B_{yy}$ and $B_n = B_{xy} = B_{yx}$
$$\vec{B} = B_n(x\hat{y} + y\hat{x}) + B_s(x\hat{x} - y\hat{y})$$
 - Quadrupole fields, either normal B_n or skew B_s
 - 180 degree (π) rotational symmetry
 - 90 degree rotation interchanges normal/skew
 - Higher order...

Visualizing Fields I

Dipole and “skew” dipole
 $n = 1$

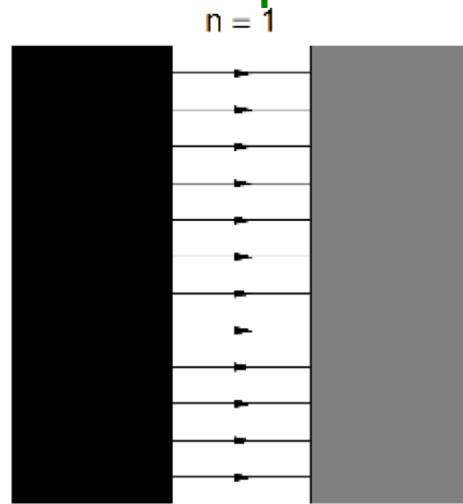
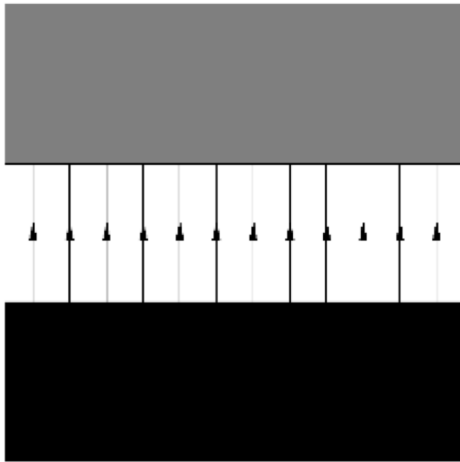

Quad and skew quad
 $n = 2$

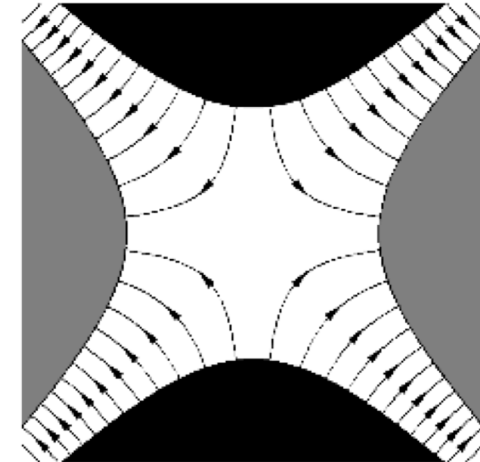
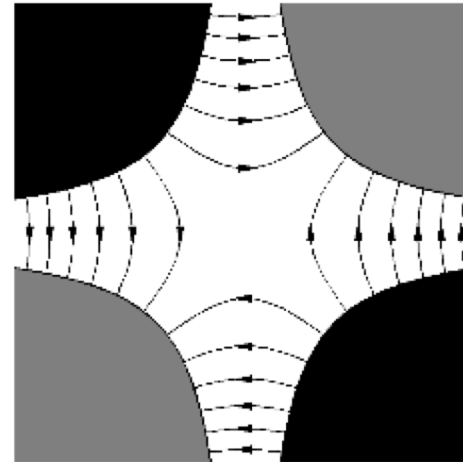

Sextupole and skew sextupole
 $n = 3$

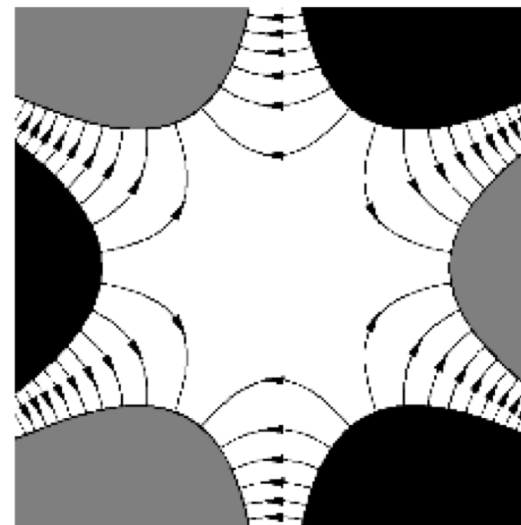
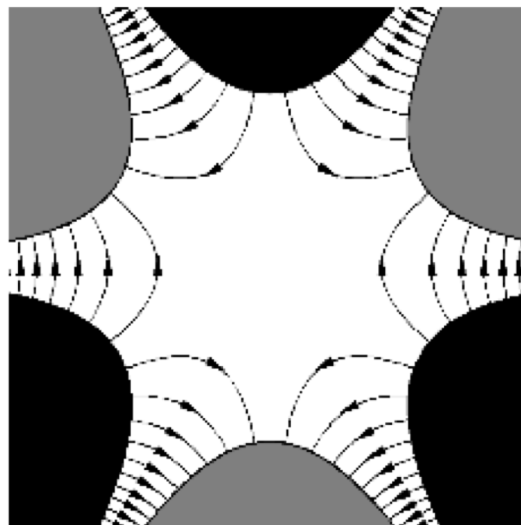

Visualizing Dipole and Quadrupole Fields II

LHC
dipole
field

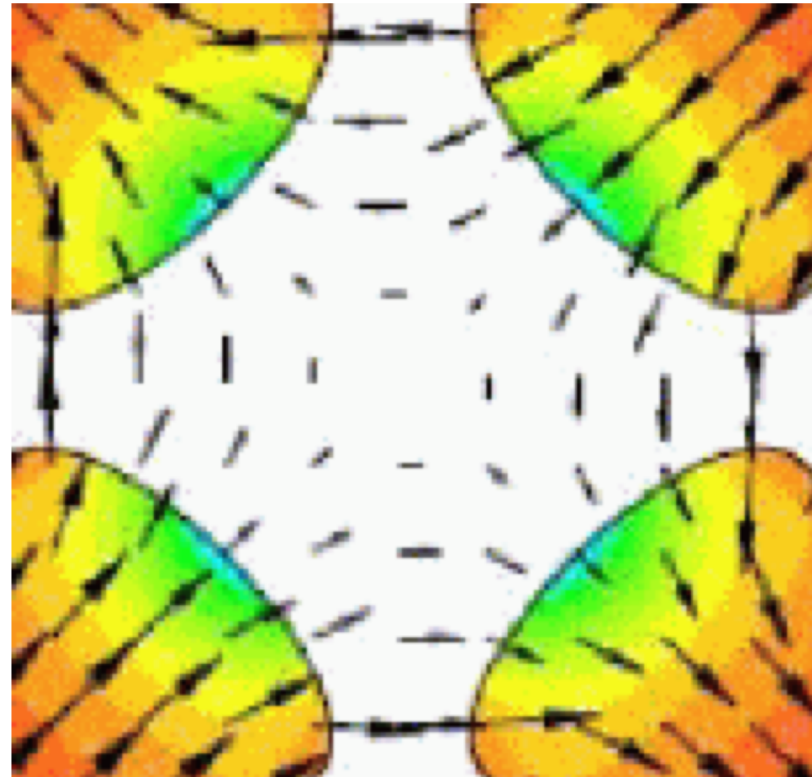
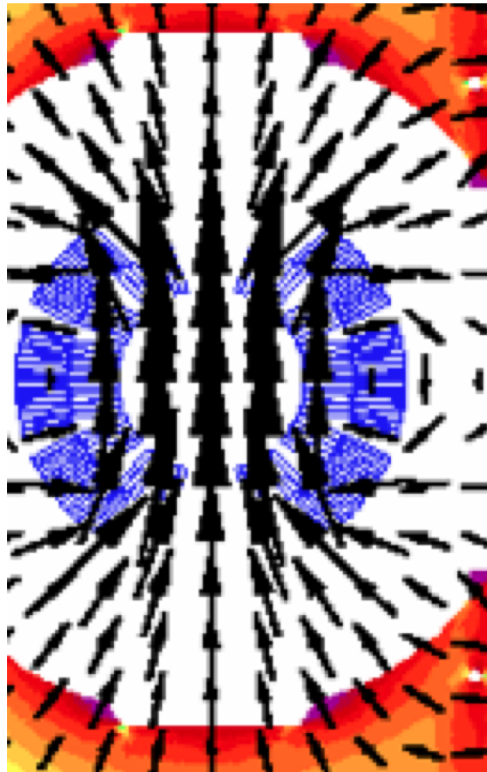

LEP
quadrupole
field

- LHC dipole: B_y gives horizontal bending
- LEP quadrupole: B_y on x axis, B_x on y axis
 - Horizontal focusing=vertical defocusing or vice-versa
 - No coupling between horizontal/vertical motion
 - Note the nice “harmonic” field symmetries

General Multipole Field Expansions

- Rotational symmetries, cylindrical coordinates
 - Power series in radius r with angular harmonics in θ

$$x = r \cos \theta \quad y = r \sin \theta$$

$$B_y = B_0 \sum_{n=0}^{\infty} \left(\frac{r}{a}\right)^n (b_n \cos n\theta - a_n \sin n\theta)$$

$$B_x = B_0 \sum_{n=0}^{\infty} \left(\frac{r}{a}\right)^n (a_n \cos n\theta + b_n \sin n\theta)$$

- Need “reference radius” a (to get units right)
- (b_n, a_n) are called (normal, skew) **multipole coefficients**
- We can also write this succinctly using de Moivre as

$$B_x - iB_y = B_0 \sum_{n=0}^{\infty} (a_n - ib_n) \left(\frac{x + iy}{a}\right)^n$$

(But Do These Equations Solve Maxwell?)

- Yes ☺ Convert Maxwell's eqns to cylindrical coords

$$\frac{\partial B_x}{\partial x} + \frac{\partial B_y}{\partial y} = 0 \quad \frac{\partial B_x}{\partial y} - \frac{\partial B_y}{\partial x} = 0$$

$$\frac{\partial(\rho B_\rho)}{\partial \rho} + \frac{\partial B_\theta}{\partial \theta} = 0 \quad \frac{\partial(\rho B_\theta)}{\partial \rho} - \frac{\partial B_\rho}{\partial \theta} = 0$$

- Aligning r along the x -axis it's easy enough to see

$$\frac{\partial}{\partial x} \Rightarrow \frac{\partial}{\partial r} \quad \frac{\partial}{\partial y} \Rightarrow \frac{1}{r} \frac{\partial}{\partial \theta}$$

- In general it's (much, much) more tedious but it works

$$\frac{\partial r}{\partial x} = \frac{1}{\cos \theta}, \quad \frac{\partial \theta}{\partial x} = \frac{-1}{r \sin \theta}, \quad \frac{\partial r}{\partial y} = \frac{1}{\sin \theta}, \quad \frac{\partial \theta}{\partial y} = \frac{1}{r \cos \theta}$$

$$\frac{\partial B_x}{\partial x} = \frac{\partial B_x}{\partial r} \frac{\partial r}{\partial x} + \frac{\partial B_x}{\partial \theta} \frac{\partial \theta}{\partial x} \dots$$

Multipoles

$(b,a)_n$ “unit” is 10^{-4} (natural scale) $(b,a)_n$ (US) = $(b,a)_{n+1}$

coefficient	multipole	field	notes
b_0	normal dipole	$B_y = B_0 b_0$	horz. bending
a_0	skew dipole	$B_x = B_0 a_0$	vert. bending
b_1	normal quadrupole	$B_x = B_0 \left(\frac{r}{a}\right) b_1 \sin \theta = B_0 \left(\frac{y}{a}\right) b_1$ $B_y = B_0 \left(\frac{r}{a}\right) b_1 \cos \theta = B_0 \left(\frac{x}{a}\right) b_1$	focusing defocusing
a_1	skew quadrupole	$B_x = B_0 \left(\frac{r}{a}\right) a_1 \cos \theta = B_0 \left(\frac{x}{a}\right) a_1$ $B_y = -B_0 \left(\frac{r}{a}\right) a_1 \sin \theta = -B_0 \left(\frac{y}{a}\right) a_1$	coupling
b_2	normal sextupole	$B_x = B_0 \left(\frac{r}{a}\right)^2 b_2 \sin(2\theta)$ $B_y = B_0 \left(\frac{r}{a}\right)^2 b_1 \cos(2\theta)$	nonlinear!

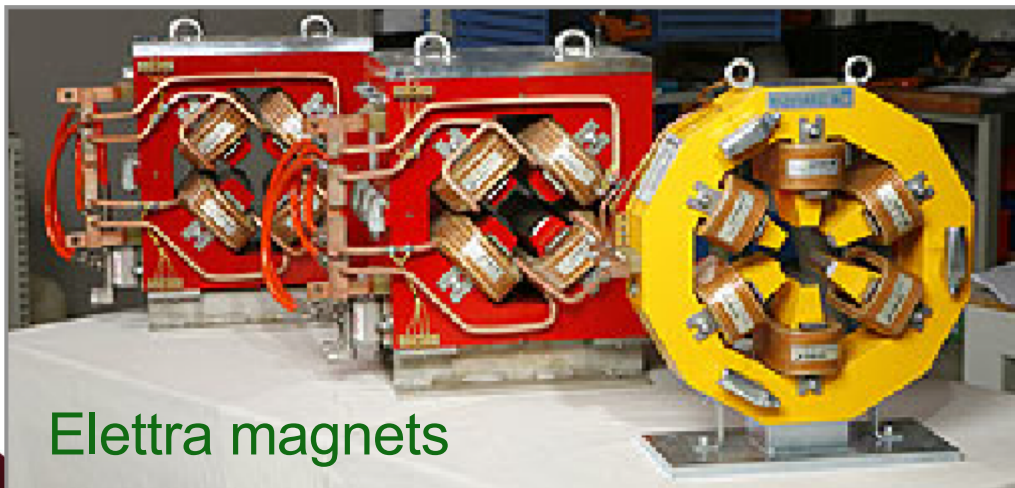

Elettra magnets

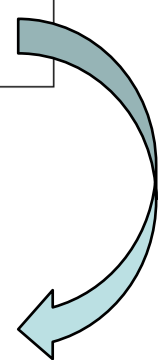
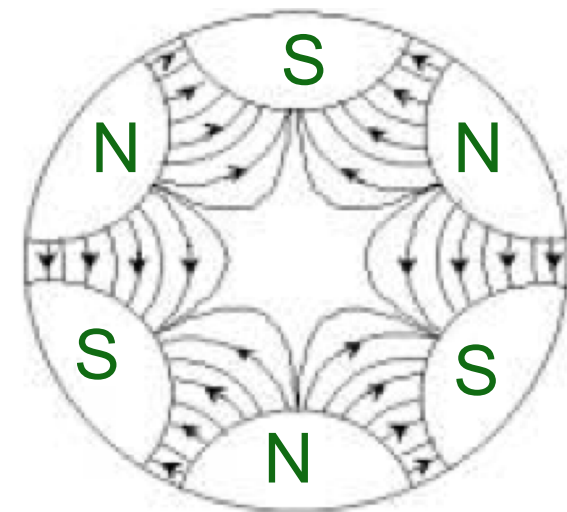

Multipole Symmetries

- Dipole has 2π rotation symmetry (or π upon current reversal)
- Quad has π rotation symmetry (or $\pi/2$ upon current reversal)
- k-pole has $2\pi/k$ rotation symmetry upon current reversal
- We try to enforce symmetries in design/construction
 - Limits permissible magnet errors
 - Higher order fields that obey main field symmetry are called allowed multipoles

RCMS half-dipole laminations
(W. Meng, BNL)

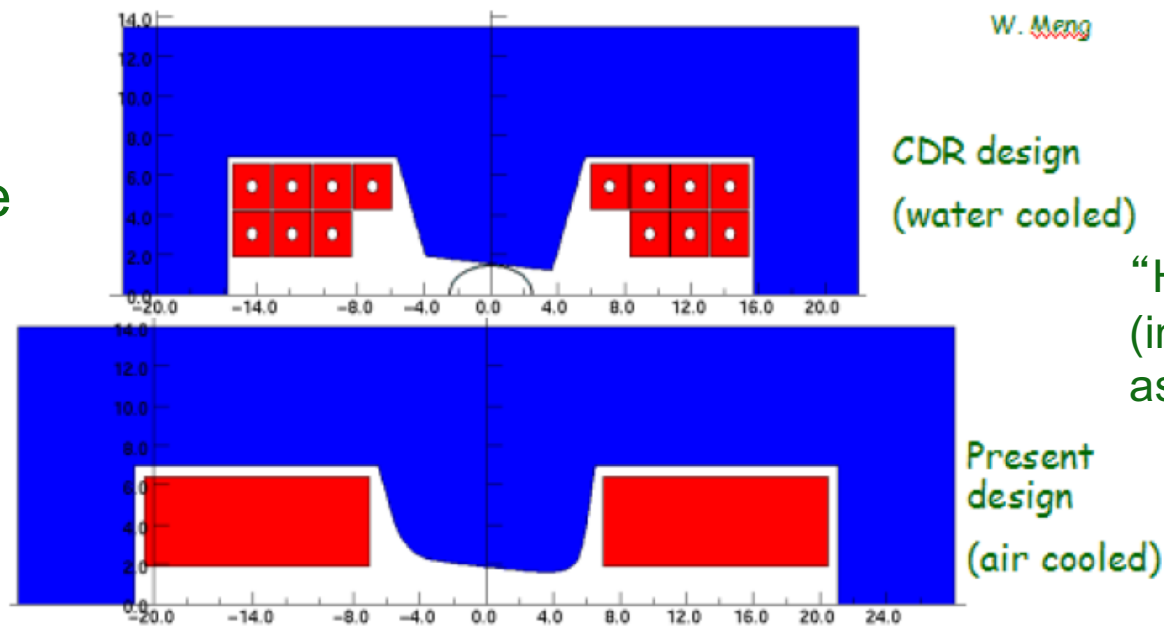

“H style dipoles”
(include focusing
as well as bending)

Multipole Symmetries II

- So a dipole ($n=0$, 2 poles) has allowed multipoles:
 - Sextupole ($n=2$, 6 poles), Decapole ($n=4$, 10 poles)...
- A quadrupole ($n=1$, 4 poles) has allowed multipoles:
 - Dodecapole ($n=5$, 12 poles), Twenty-pole ($n=9$, 20 poles)...
- General allowed multipoles: $(2k+1)(n+1)-1$
 - Or, more conceptually, (3,5,7,...) times number of poles
- Other multipoles are forbidden by symmetries
 - Smaller than allowed multipoles, but no magnets are perfect
 - Large measured forbidden multipoles mean fabrication or fundamental design problems!
- Better magnet pole face quality with punched laminations
- Dynamics are usually dominated by lower-order multipoles

Equipotentials and Contours

Z. Guo et al, NIM:A 691,
pp. 97-108, 1 Nov 2012. A novel structure of multipole field
magnets and their applications in uniformizing beam spot at target

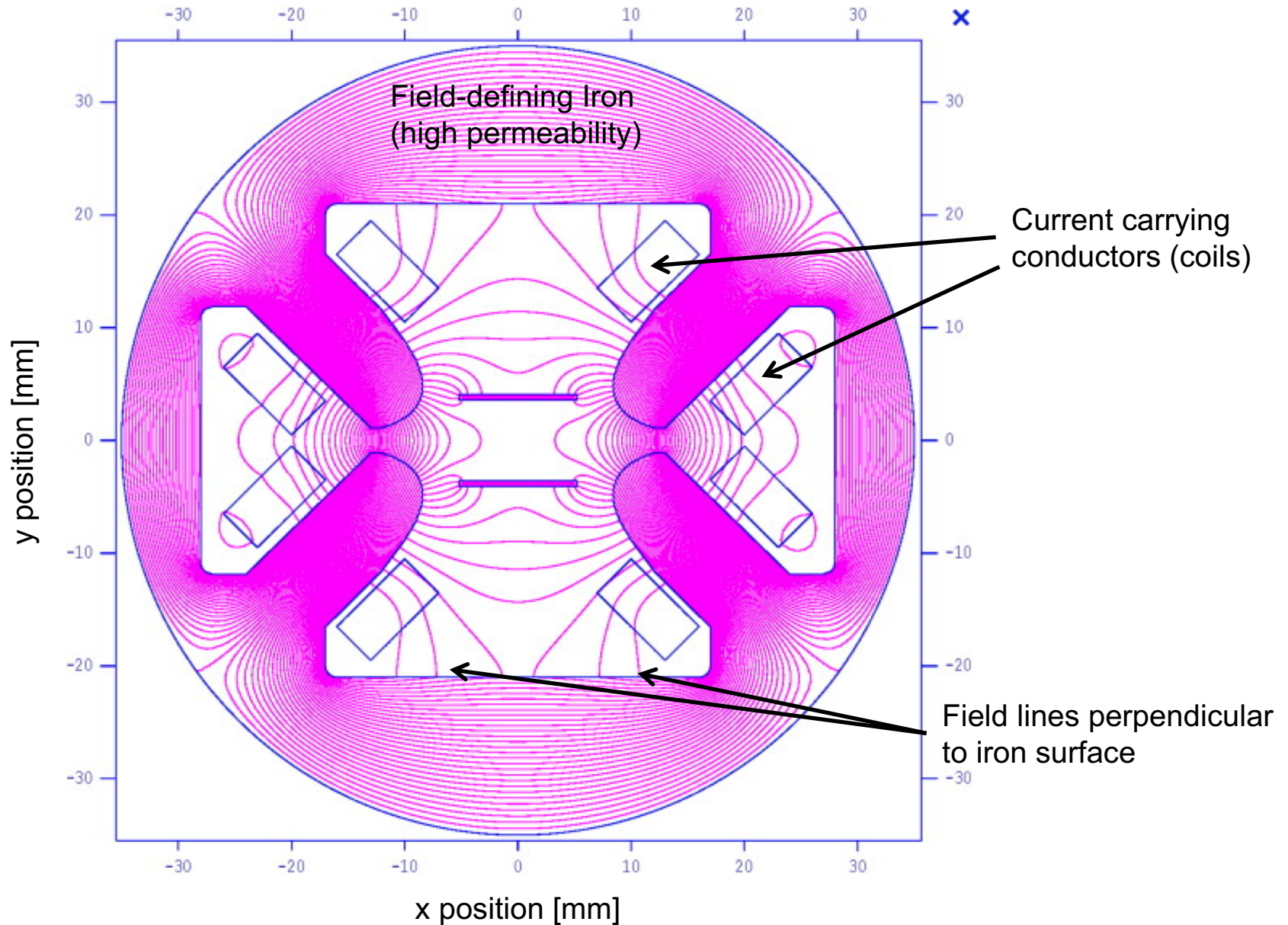

Equipotentials and Contours

- Let's get around to designing some magnets
 - Conductors on outside, field on inside
 - Use high-permeability iron to shape fields: **iron-dominated**
 - Pole faces are very nearly equipotentials
 - We work with a magnetostatic *scalar* potential Ψ
 - B, H field lines are perpendicular to equipotential lines of Ψ

$$\vec{H} = -\vec{\nabla}\Psi$$

$$\Psi = \sum_{n=0}^{\infty} \frac{a}{n+1} \left(\frac{r}{a}\right)^{n+1} [F_n \cos((n+1)\theta) + G_n \sin((n+1)\theta)]$$

$$\text{where } G_n \equiv B_0 b_n / \mu_0, F_n \equiv B_0 a_n / \mu_0$$

This comes from integrating our B field expansion.
Let's look at normal multipoles G_n and pole faces...

Equipotentials and Contours II

- For general G_n normal multipoles (i.e. for b_n)

$$\Psi(\text{equipotential for } b_n) \propto r^{n+1} \sin[(n+1)\theta] = \text{constant}$$

- Dipole ($n=0$): $\Psi(\text{dipole}) \propto r \sin \theta = y$
 - Normal dipole pole faces are $y=\text{constant}$
- Quadrupole ($n=1$):

$$\Psi(\text{quadrupole}) \propto r^2 \sin(2\theta) = 2xy$$

- Normal quadrupole pole faces are $xy=\text{constant}$ (hyperbolic)

- So what conductors and currents are needed to generate these fields?

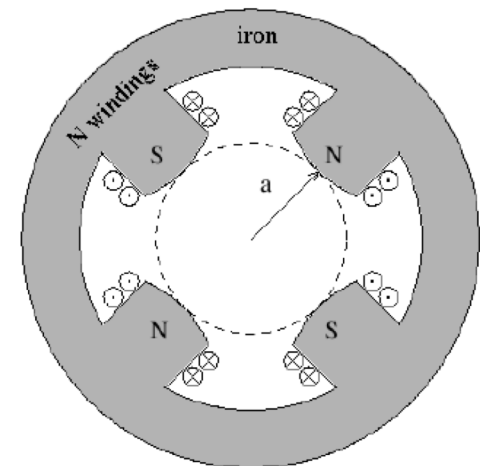
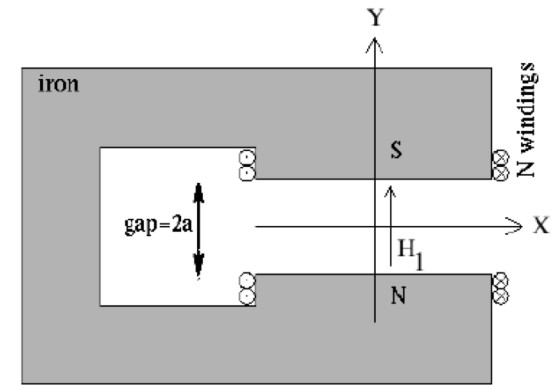

Dipole Field/Current

- Use Ampere's law to calculate field in gap
 - N "turns" of conductor around each pole
 - Each turn of conductor carries current I

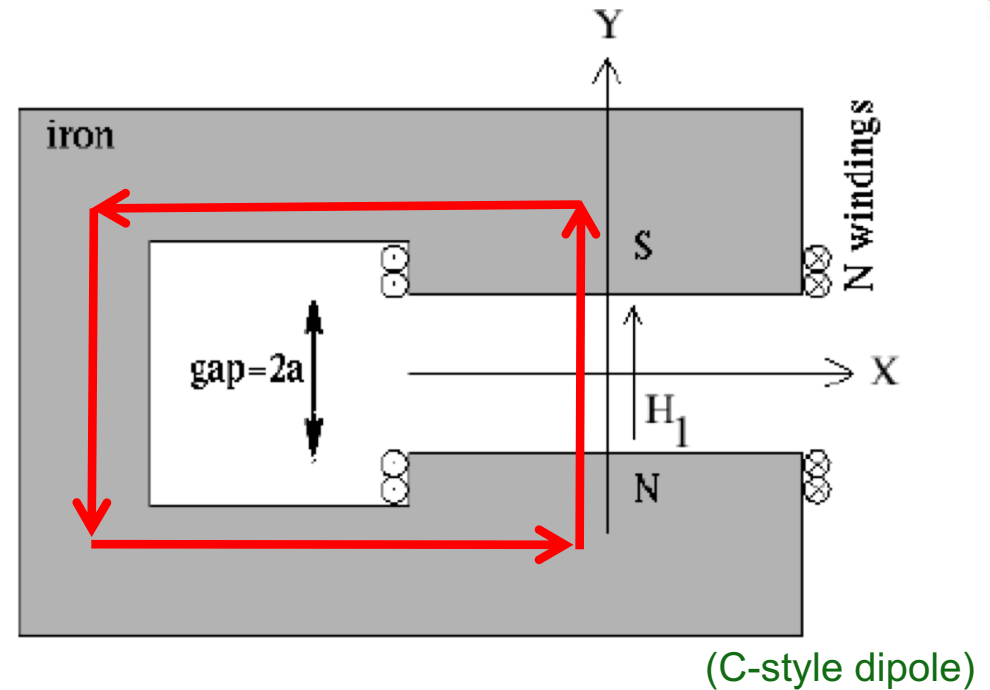

- Field integral is through N-S poles and (highly permeable) iron (including return path)

$$2NI = \oint \vec{H} \cdot d\vec{l} = 2aH \Rightarrow H = \frac{NI}{a}, \quad B = \frac{\mu_0 NI}{a}$$

- NI is in "Amp-turns", $\mu_0 \sim 1.257 \text{ cm-G/A}$

$$\Delta x' = \frac{BL}{(B\rho)}$$
 - So $a=2\text{cm}$, $B=600\text{G}$ requires $NI \sim 955 \text{ Amp-turns}$

Wait, What's That $\Delta x'$ Equation?

$$\Delta x' = \frac{BL}{(B\rho)} \quad \leftarrow \text{Field, length: Properties of magnet}$$

$$\quad \leftarrow \text{Rigidity: property of beam (really } p/q\text{)}$$

- This is the angular transverse kick from a thin hard-edge dipole, like a dipole corrector
 - Really a change in p_x but paraxial approximation applies
 - The B in $(B\rho)$ is not necessarily the main dipole B
 - The ρ in $(B\rho)$ is not necessarily the ring circumference/ 2π
 - And neither is related to this particular dipole kick!

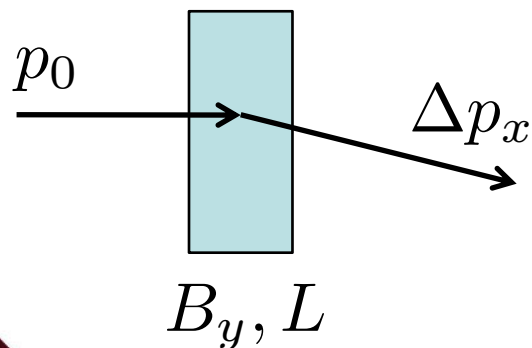

$$F_x = \frac{\Delta p_x}{\Delta t} = q(\beta c)B_y \quad \Delta t = L/(\beta c)$$

$$\Delta p_x = qLB_y$$

$$\Delta x' \approx \frac{\Delta p_x}{p} = \frac{q}{p}LB_y = \frac{B_y L}{(B\rho)}$$

Quadrupole Field/Current

- Use Ampere's law again
 - Easiest to do with magnetic potential Ψ , encloses $2NI$

$$\Psi(a, \theta) = \frac{a B_0 b_1}{2 \mu_0} \sin(2\theta)$$

$$2NI = \oint \vec{H} \cdot d\vec{l} = \Psi(a, \pi/4) - \Psi(a, -\pi/4) = \frac{a B_0 b_1}{\mu_0}$$

$$\Psi = NI \sin(2\theta) = \frac{2NI}{a^2} xy$$

$$\vec{H} = \nabla \Psi = \frac{2NI}{a^2} (y\hat{x} + x\hat{y}) \quad \vec{B} = \frac{2\mu_0 NI}{a^2} (y\hat{x} + x\hat{y})$$

- Quadrupole strengths are expressed as transverse gradients

$$B' \equiv \left. \frac{\partial B_y}{\partial x} \right|_{y=0} = \frac{\partial B_x}{\partial y} = \frac{2\mu_0 NI}{a^2} \quad \Delta x' = \frac{B' L}{(B\rho)} x$$

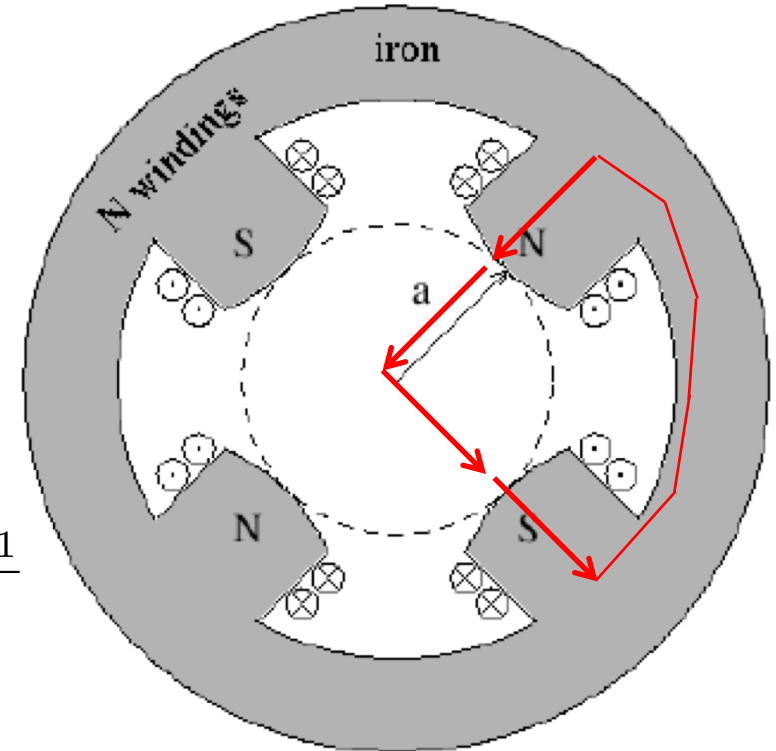

(NB: Be careful, ' has different meaning in B', B'', B''' ...)

Quadrupole Transport Matrix

- Paraxial equations of motion for constant quadrupole field

$$\frac{d^2 x}{ds^2} + kx = 0 \qquad \frac{d^2 y}{ds^2} - ky = 0 \qquad s \equiv \beta ct$$

$$k \equiv \frac{B'}{(B\rho)} = \frac{2\mu_0 NI}{a^2} \left(\frac{q}{p} \right)$$

- Integrating over a magnet of length L gives (exactly)

Focusing
Quadrupole

$$\begin{pmatrix} x \\ x' \end{pmatrix} = \begin{pmatrix} \cos(L\sqrt{k}) & \frac{1}{\sqrt{k}} \sin(L\sqrt{k}) \\ -\sqrt{k} \sin(L\sqrt{k}) & \cos(L\sqrt{k}) \end{pmatrix} \begin{pmatrix} x_0 \\ x'_0 \end{pmatrix} = \mathbf{M}_F \begin{pmatrix} x_0 \\ x'_0 \end{pmatrix}$$

Defocusing
Quadrupole

$$\begin{pmatrix} y \\ y' \end{pmatrix} = \begin{pmatrix} \cosh(L\sqrt{k}) & \frac{1}{\sqrt{k}} \sinh(L\sqrt{k}) \\ \sqrt{k} \sinh(L\sqrt{k}) & \cosh(L\sqrt{k}) \end{pmatrix} \begin{pmatrix} y_0 \\ y'_0 \end{pmatrix} = \mathbf{M}_D \begin{pmatrix} y_0 \\ y'_0 \end{pmatrix}$$

Thin Quadrupole Transport Matrix

Focusing Quadrupole $\begin{pmatrix} x \\ x' \end{pmatrix} = \begin{pmatrix} \cos(L\sqrt{k}) & \frac{1}{\sqrt{k}} \sin(L\sqrt{k}) \\ -\sqrt{k} \sin(L\sqrt{k}) & \cos(L\sqrt{k}) \end{pmatrix} \begin{pmatrix} x_0 \\ x'_0 \end{pmatrix} = \mathbf{M}_F \begin{pmatrix} x_0 \\ x'_0 \end{pmatrix}$

Defocusing Quadrupole $\begin{pmatrix} y \\ y' \end{pmatrix} = \begin{pmatrix} \cosh(L\sqrt{k}) & \frac{1}{\sqrt{k}} \sinh(L\sqrt{k}) \\ \sqrt{k} \sinh(L\sqrt{k}) & \cosh(L\sqrt{k}) \end{pmatrix} \begin{pmatrix} y_0 \\ y'_0 \end{pmatrix} = \mathbf{M}_D \begin{pmatrix} y_0 \\ y'_0 \end{pmatrix}$

- Quadrupoles are often “thin”
 - Focal length is much longer than magnet length
- Then we can use the thin-lens approximation $L\sqrt{k} \ll 1$

Thin quadrupole approximation

$$\mathbf{M}_{F,D} = \begin{pmatrix} 1 & 0 \\ \mp kL & 1 \end{pmatrix} = \begin{pmatrix} 1 & 0 \\ \mp \frac{1}{f} & 1 \end{pmatrix}$$

where $f=1/(kL)$ is the quadrupole focal length

$$\Delta x' = \frac{B' L}{(B\rho)} x$$

Picturing Drift and Quadrupole Motion

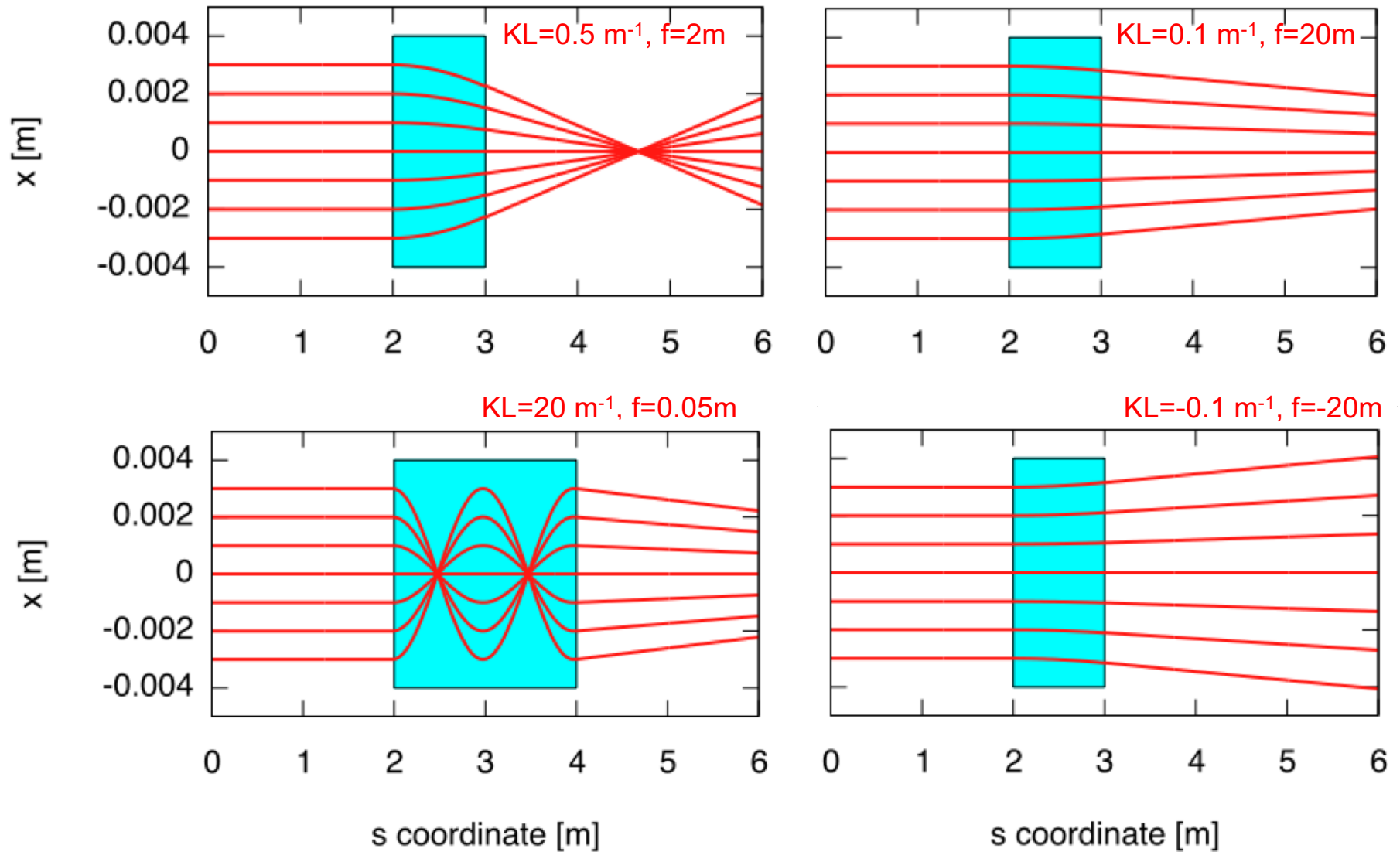

Picturing Drift and Quadrupole Motion

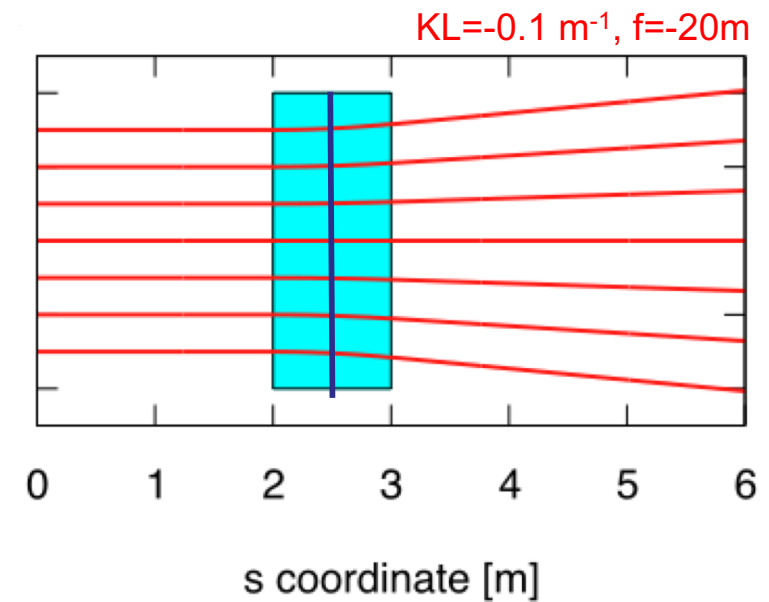
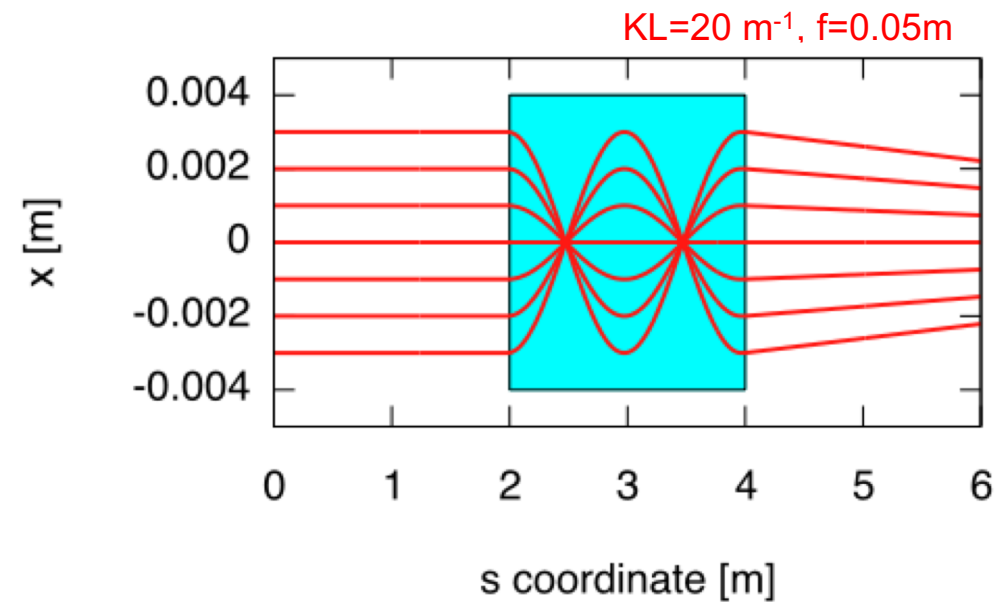
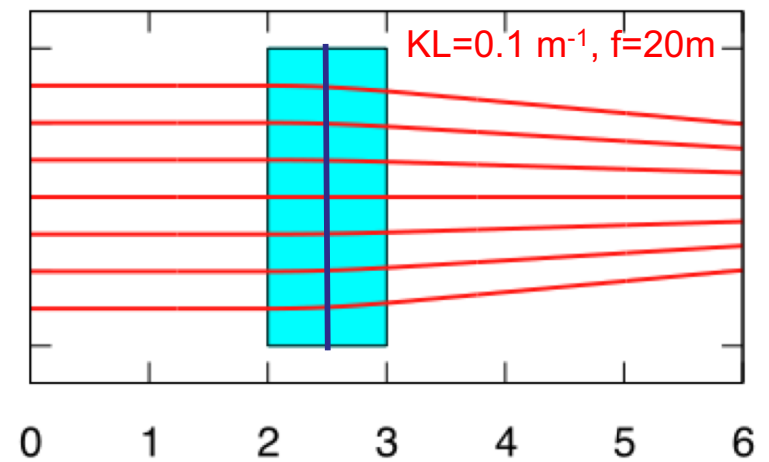
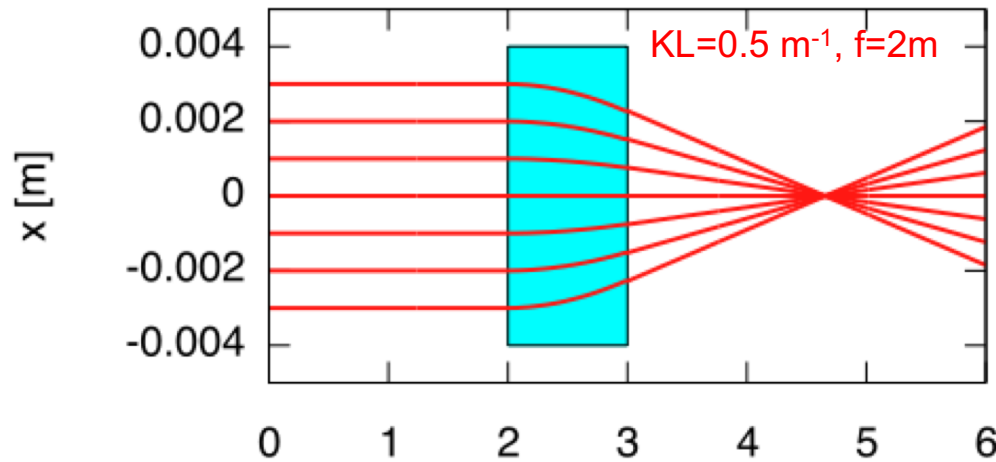

Thin Quadrupole Approximations

Higher Orders

- We can follow the full expansion for 2(n+1)-pole:

$$\Psi_n = NI \left(\frac{r}{a}\right)^{n+1} \sin((n+1)\theta)$$

$$H_x = (n+1) \frac{NI}{a} \left(\frac{r}{a}\right)^n \sin n\theta \quad H_y = (n+1) \frac{NI}{a} \left(\frac{r}{a}\right)^n \cos n\theta$$

- For the sextupole (n=2) we find the nonlinear field as

$$\vec{B} = \frac{3\mu_0 NI}{a^3} [2xy\hat{x} + (x^2 - y^2)\hat{y}]$$

- Now define a strength as an nth derivative

$$B'' \equiv \frac{\partial^2 B_y}{\partial x^2} \Big|_{y=0} = \frac{6\mu_0 NI}{a^3} \quad \Delta x' = \frac{1}{2} \frac{B'' L}{(B\rho)} (x^2 - y^2)$$

(NB: Be careful, ' has different meaning in B', B'', B'''...)

Hysteresis

- Magnets with variable current carry “memory”

Hysteresis is quite important in iron-dominated magnets

- Usually try to run magnets “on hysteresis”

e.g. always on one side of hysteresis loop

Large spread at large field (1+ T): saturation

Degaussing

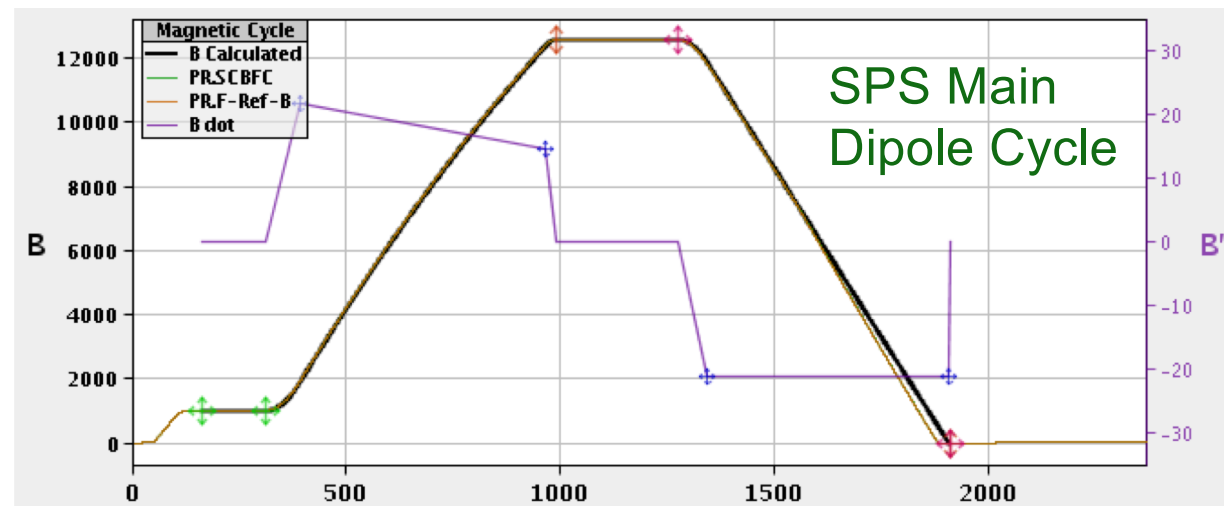
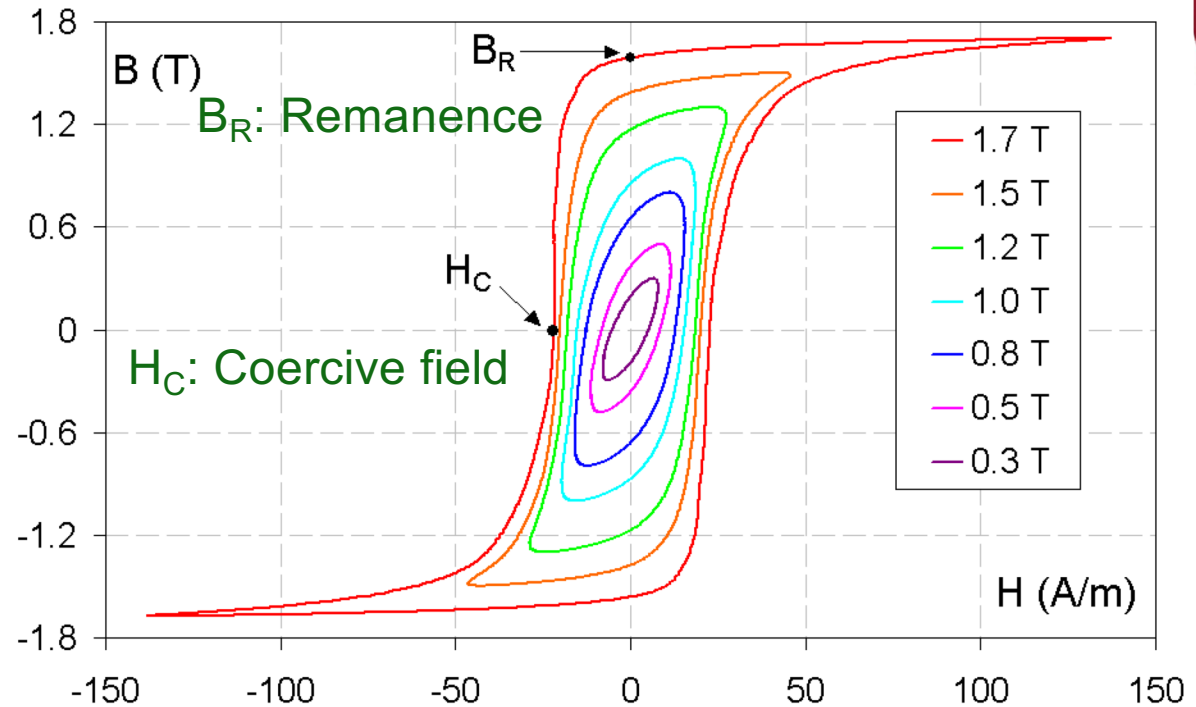

End Fields

- Magnets are not infinitely long: ends are important!
 - Conductors: where coils usually come in and turn around
 - Longitudinal symmetries break down
 - Sharp corners on iron are first areas to saturate
 - Usually a concern over distances of ± 1 -2 times magnet gap
 - A big deal for short, large-aperture magnets; ends dominate!
- Solution: simulate... a lot
 - Test prototypes too
 - Quadratic end chamfer eases sextupoles from ends (first allowed harmonic of dipole)
- More on dipole end focusing...

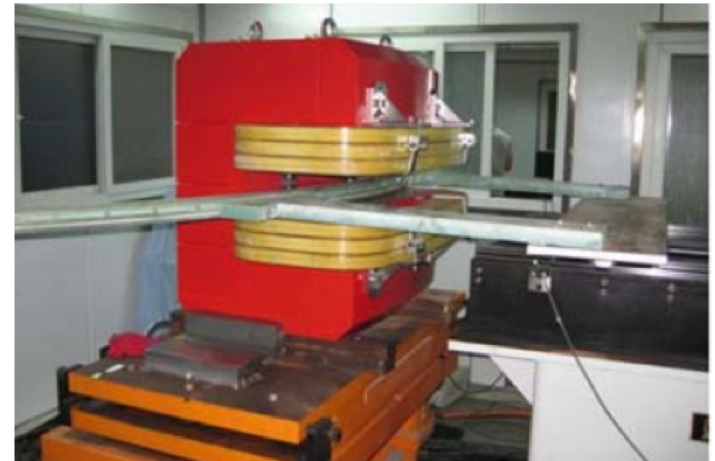

PEFP prototype magnet (Korea)
9 cm gap, 1.4m long

Dipoles, Sector and Rectangular Bends

- Sector bend (sbend)
 - Beam design entry/exit angles are perpendicular to end faces

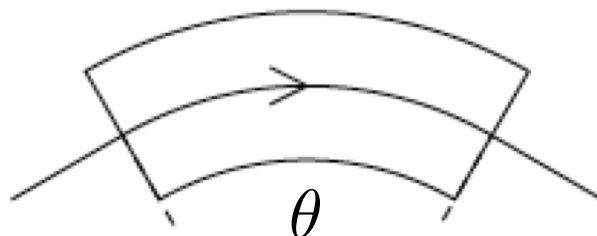

- Simpler to conceptualize, but harder to build
- Rectangular bend (rbend)
 - Beam design entry/exit angles are half of bend angle

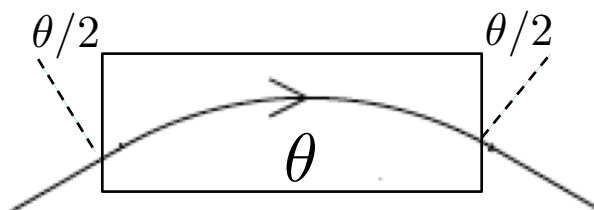

- Easier to build, but must include effects of edge focusing

Sector Bend Transport Matrix



- The dipole “rotation” that we see in phase space movies

$$M_{\text{sector dipole}} = \begin{pmatrix} \cos \theta & \rho \sin \theta & 0 & 0 & 0 & \rho(1 - \cos \theta) \\ -\frac{1}{\rho} \sin \theta & \cos \theta & 0 & 0 & 0 & \sin \theta \\ 0 & 0 & 1 & \rho\theta & 0 & 0 \\ 0 & 0 & 0 & 1 & 0 & 0 \\ -\sin \theta & -\rho(1 - \cos(\theta)) & 0 & 0 & 1 & -\rho(\theta - \sin \theta) \\ 0 & 0 & 0 & 0 & 0 & 1 \end{pmatrix}$$

Book equation A.4

- Has all the “right” behaviors
 - But what about rectangular bends?

Dipole End Angles

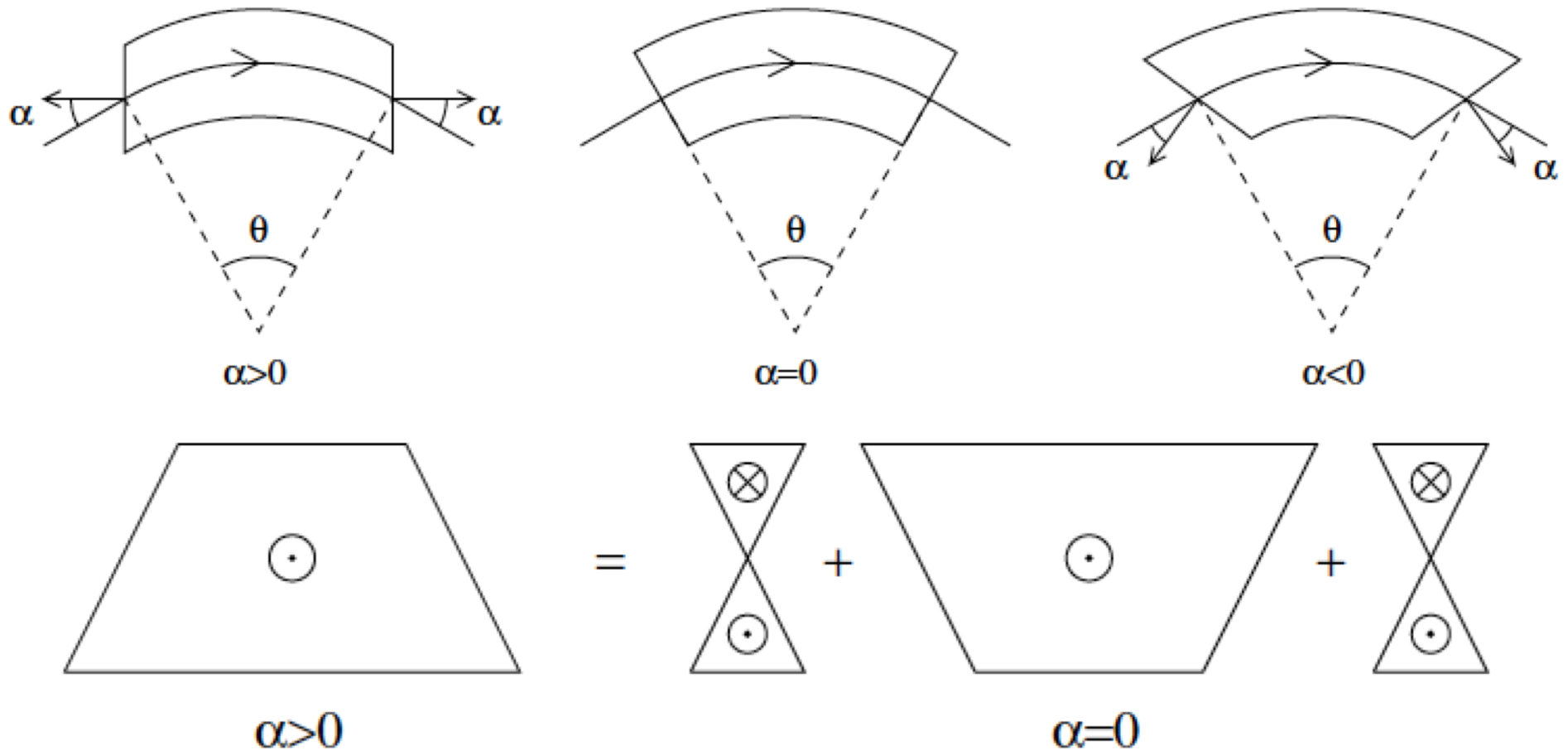

- We treat general case of symmetric dipole end angles
 - Superposition: looks like wedges on end of sector dipole
 - Rectangular bends are a special case

Kick from a Thin Wedge

- The edge focusing calculation requires the kick from a thin wedge

$$\Delta x' = \frac{B_z L}{(B\rho)}$$

What is L? (distance in wedge)

$$\tan\left(\frac{\alpha}{2}\right) = \frac{L/2}{x}$$

$$L = 2x \tan\left(\frac{\alpha}{2}\right) \approx x \tan \alpha$$

$$\text{So } \Delta x' = \frac{B_z \tan \alpha}{(B\rho)} x = \frac{\tan \alpha}{\rho} x$$

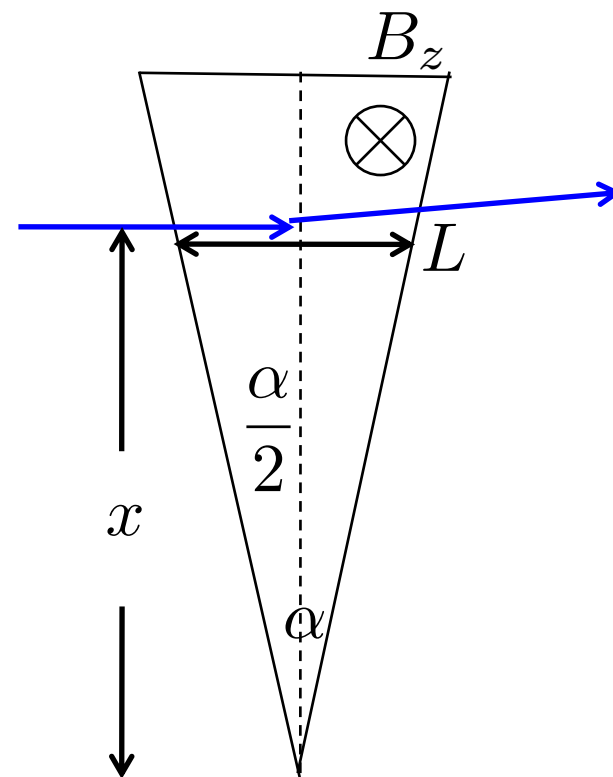

Here ρ is the curvature for a particle of this momentum!!

Dipole Matrix with Ends

- The matrix of a dipole with thick ends is then

$$M_{\text{sector dipole}}(x, x', \delta) = \begin{pmatrix} \cos \theta & \rho \sin \theta & \rho(1 - \cos \theta) \\ -\frac{1}{\rho} \sin \theta & \cos \theta & \sin \theta \\ 0 & 0 & 1 \end{pmatrix}$$

$$M_{\text{end lens}} = \begin{pmatrix} 1 & 0 & 0 \\ \frac{\tan \alpha}{\rho} & 1 & 0 \\ 0 & 0 & 1 \end{pmatrix}$$

$$M_{\text{edge-focused dipole}} = M_{\text{end lens}} M_{\text{sector dipole}} M_{\text{end lens}}$$

$$M_{\text{edge-focused dipole}} = \begin{pmatrix} \frac{\cos(\theta - \alpha)}{\cos \alpha} & \rho \sin \theta & \rho(1 - \cos \theta) \\ -\frac{\sin(\theta - 2\alpha)}{\rho \cos^2 \alpha} & \frac{\cos(\theta - \alpha)}{\cos \alpha} & \frac{\sin(\theta - \alpha) + \sin \alpha}{\cos \alpha} \\ 0 & 0 & 1 \end{pmatrix}$$

- Rectangular bend is special case where $\alpha = \theta/2$

(End Fields)

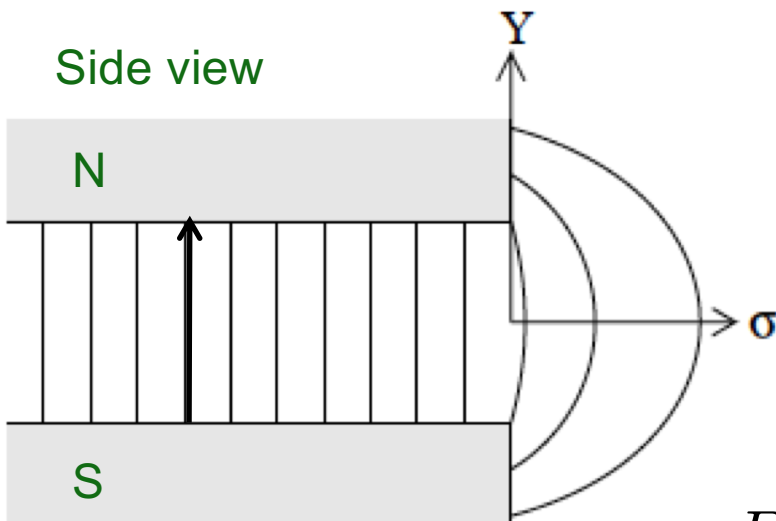

a)

$$\Delta y' = \frac{B_x l_{\text{fringe}}}{(B\rho)}$$

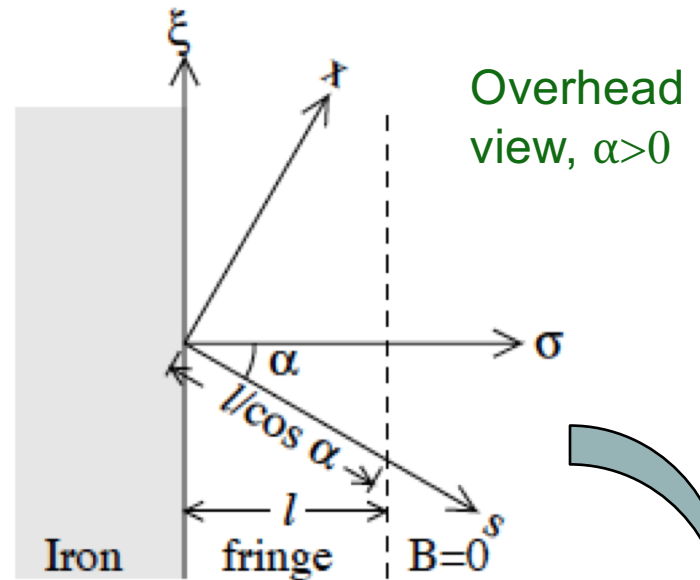

b)

Overhead view, $\alpha > 0$

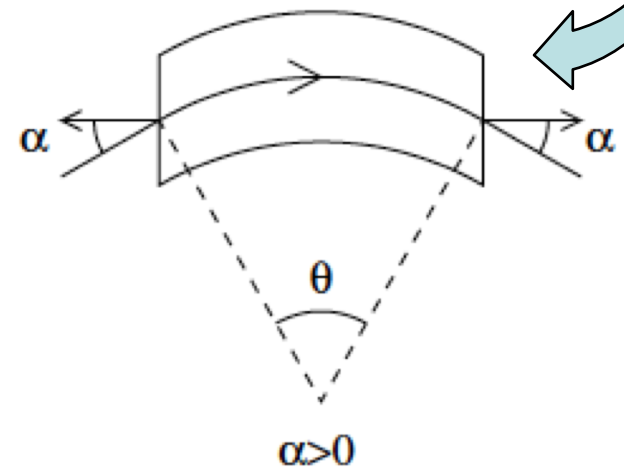

- Field lines go from $-y$ to $+y$ for a positively charged particle
 - $B_x < 0$ for $y > 0$; $B_x > 0$ for $y < 0$
 - Net focusing!
 - Field goes like $\sin(\alpha)$
 - get $\cos(\alpha)$ from integral length

Other Familiar Dipoles

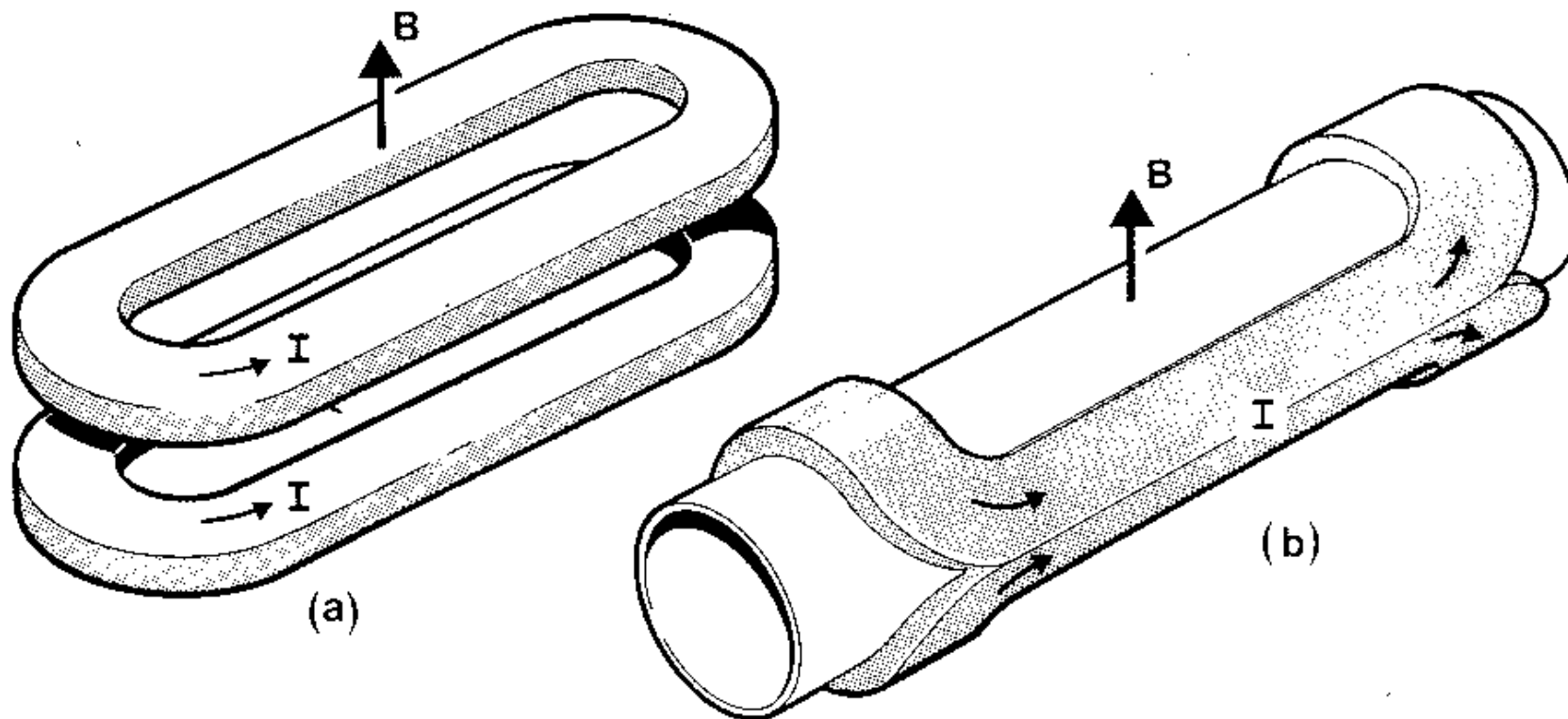

- Weaker, cheaper dipoles can be made by conforming coils to a beam-pipe (no iron)
- Relatively inexpensive, but not very precise
 - Field quality on the order of percent

Normal vs Superconducting Magnets

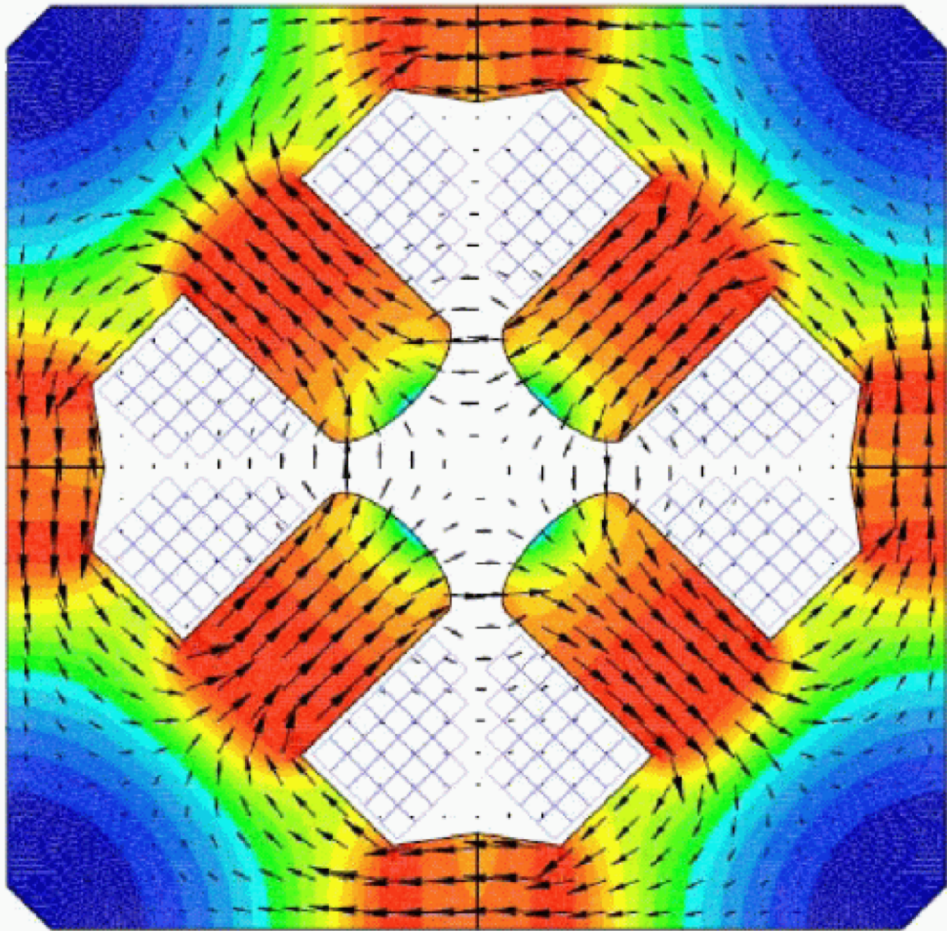

LEP quadrupole magnet
(NC)

- Note high field strengths (red) where flux lines are densely packed together

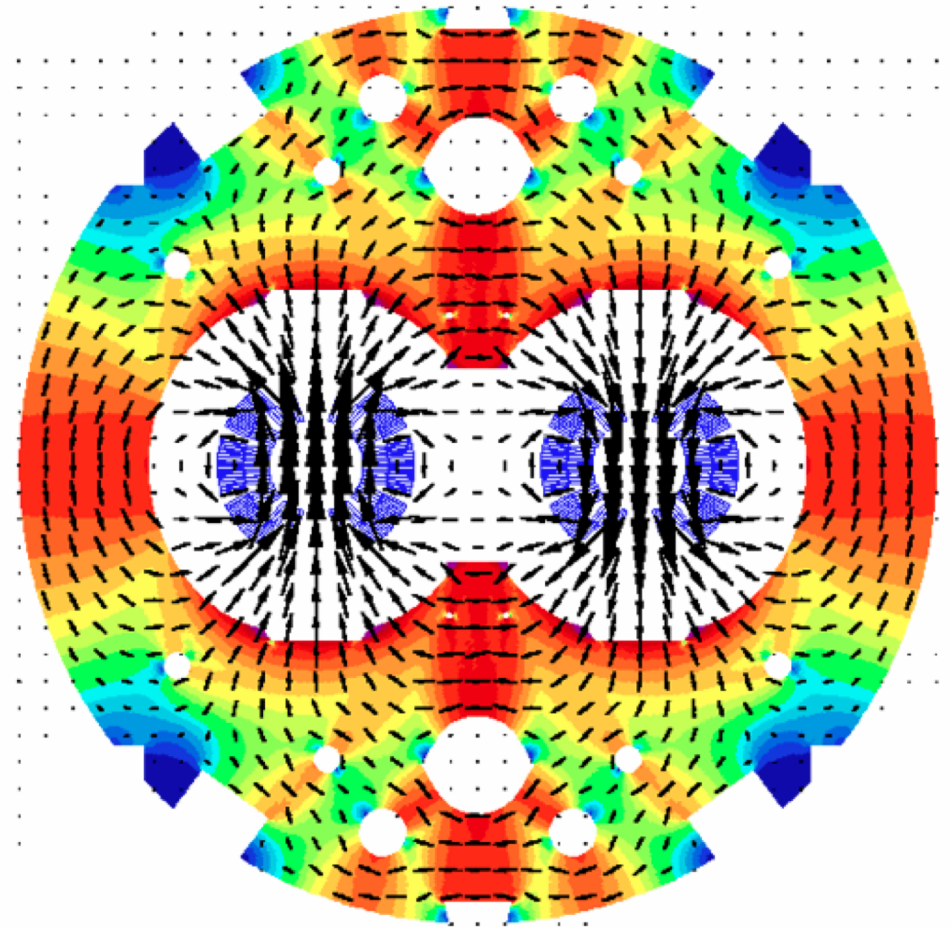

LHC dipole magnets (SC)

RHIC Dipole/Quadrupole Cross Sections

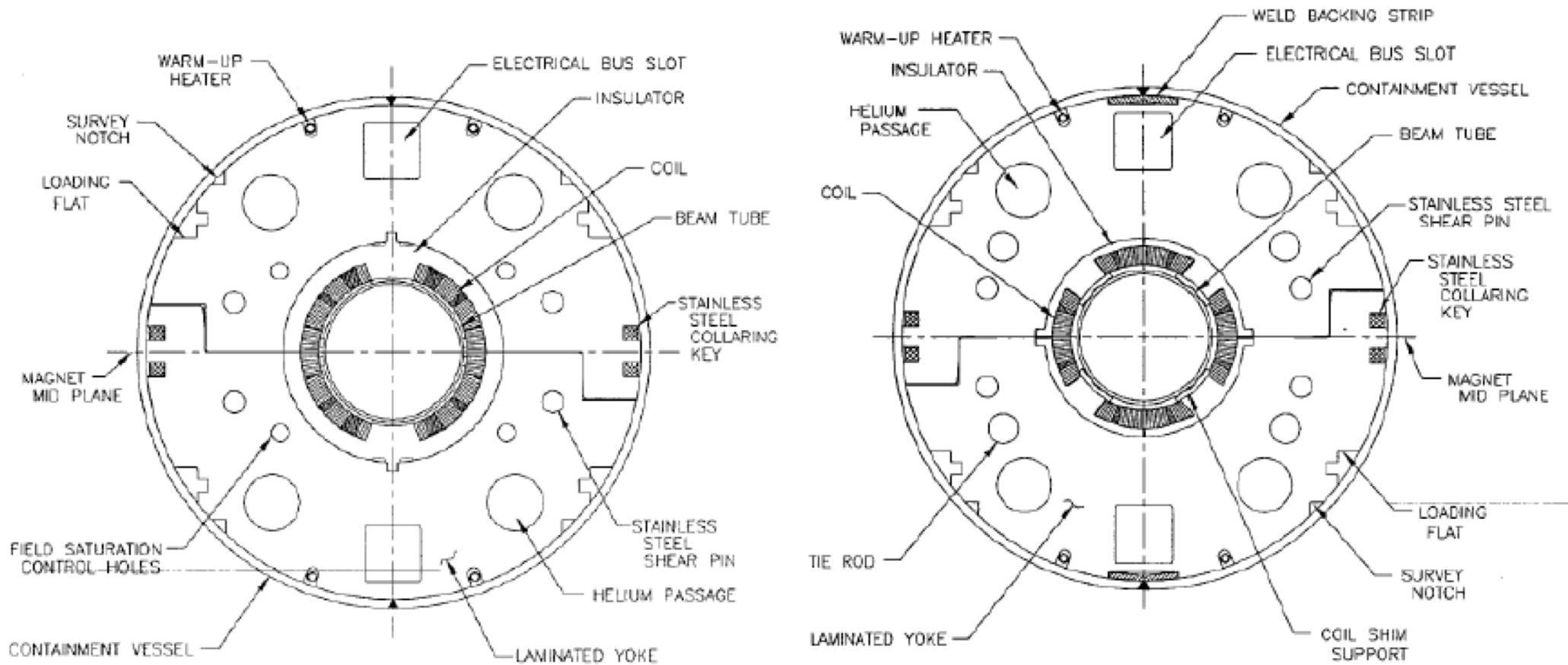

RHIC $\cos(\theta)$ -style superconducting magnets and yokes
 NbTi in Cu stabilizer, iron yokes, saturation holes
 Full field design strength is up to 20 MPa (3 kpsi)
 4.5 K, 3.45 Tesla

Rutherford Cable

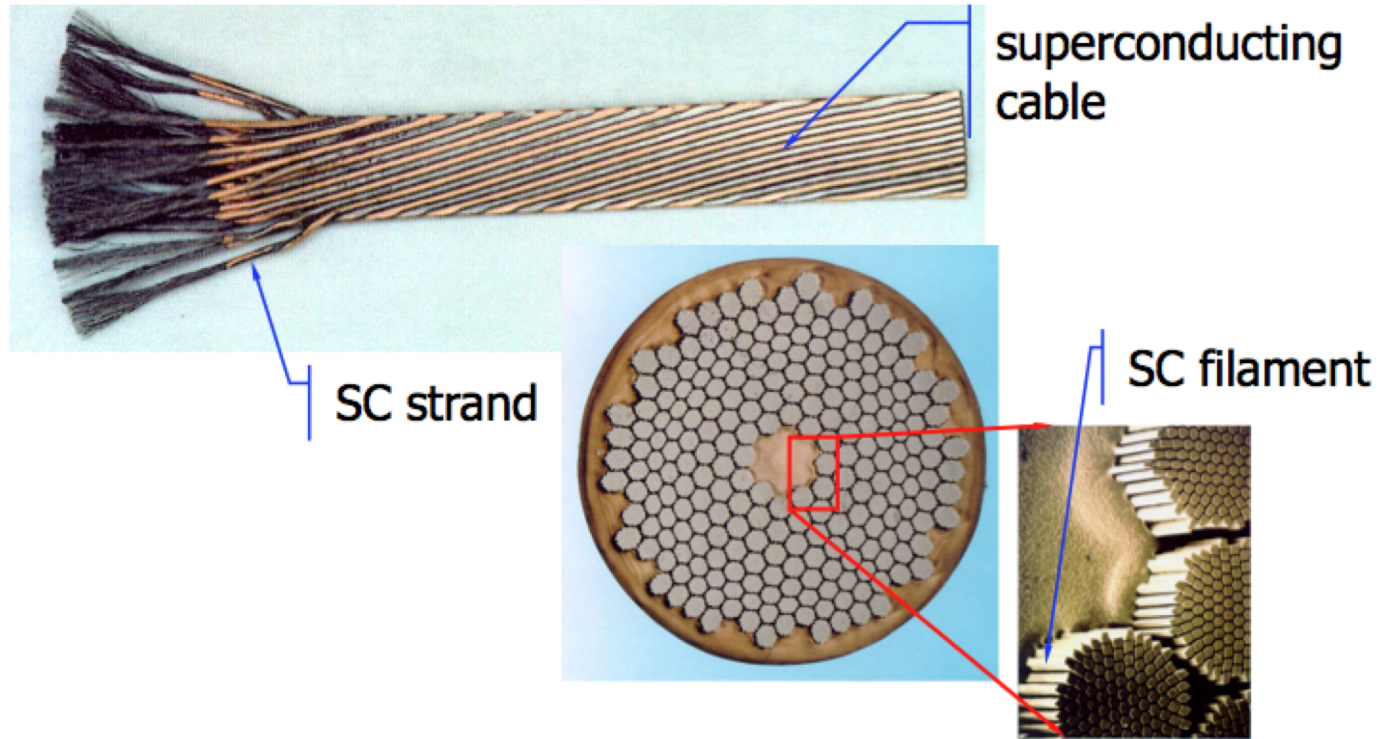

- Superconducting cables: NbTi in Cu matrix
 - Single 5 μm filament at 6T carries ~ 50 mA of current
 - Strand has 5-10k filaments, or carries 250-500 A
 - Magnet currents are often 5-10 kA: 10-40 strands in cable
 - Balance of stresses, compactable to stable high density

Superconducting Dipole Magnet Comparison

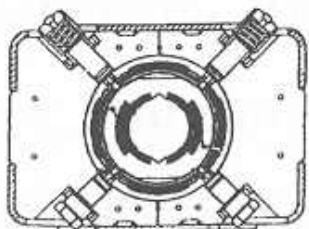

Tevatron
4T, 90mm

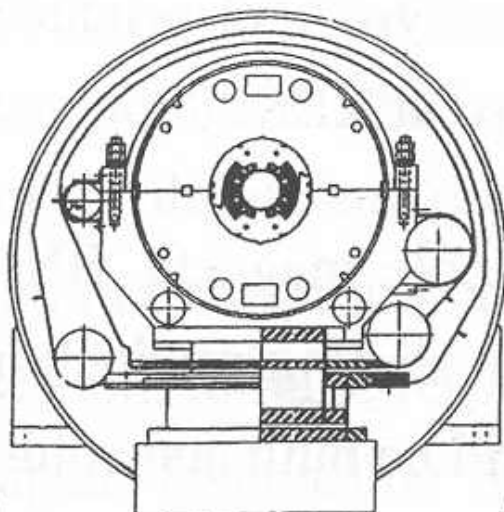

SSC

6.8 T, 50 mm

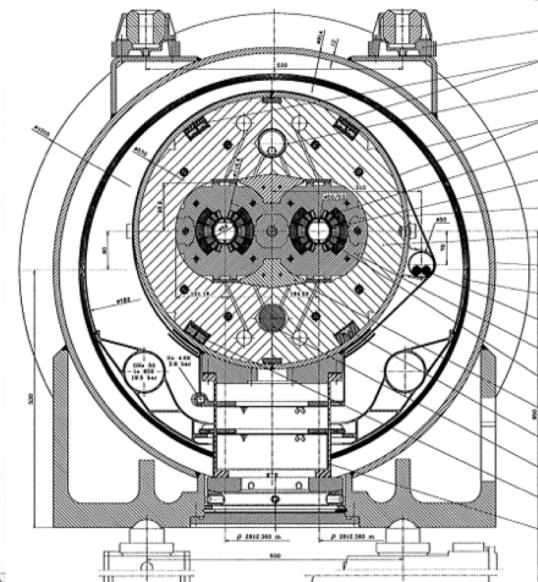

LHC

8.36T, 56mm

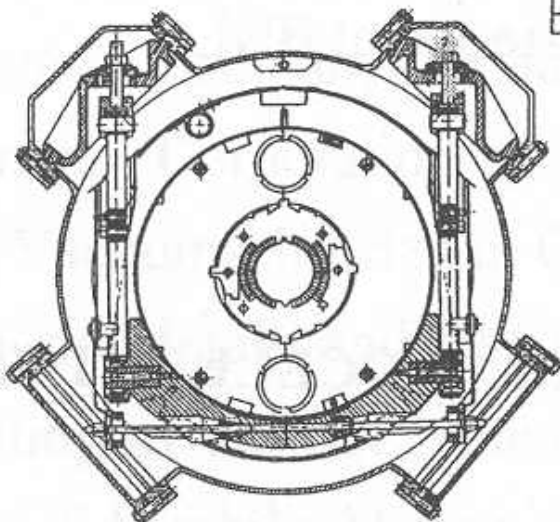

HERA

4.7T, 75 mm

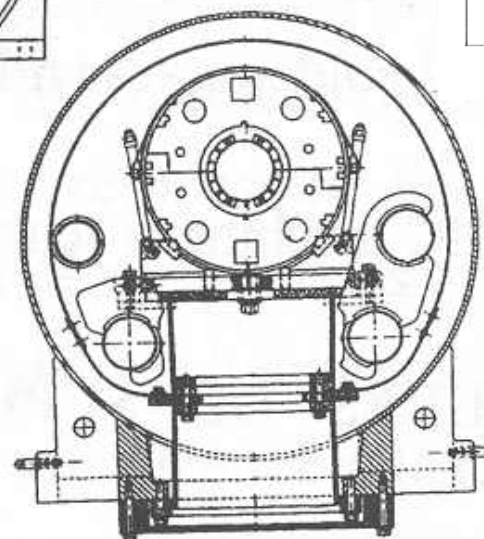

RHIC

3.4T, 80mm

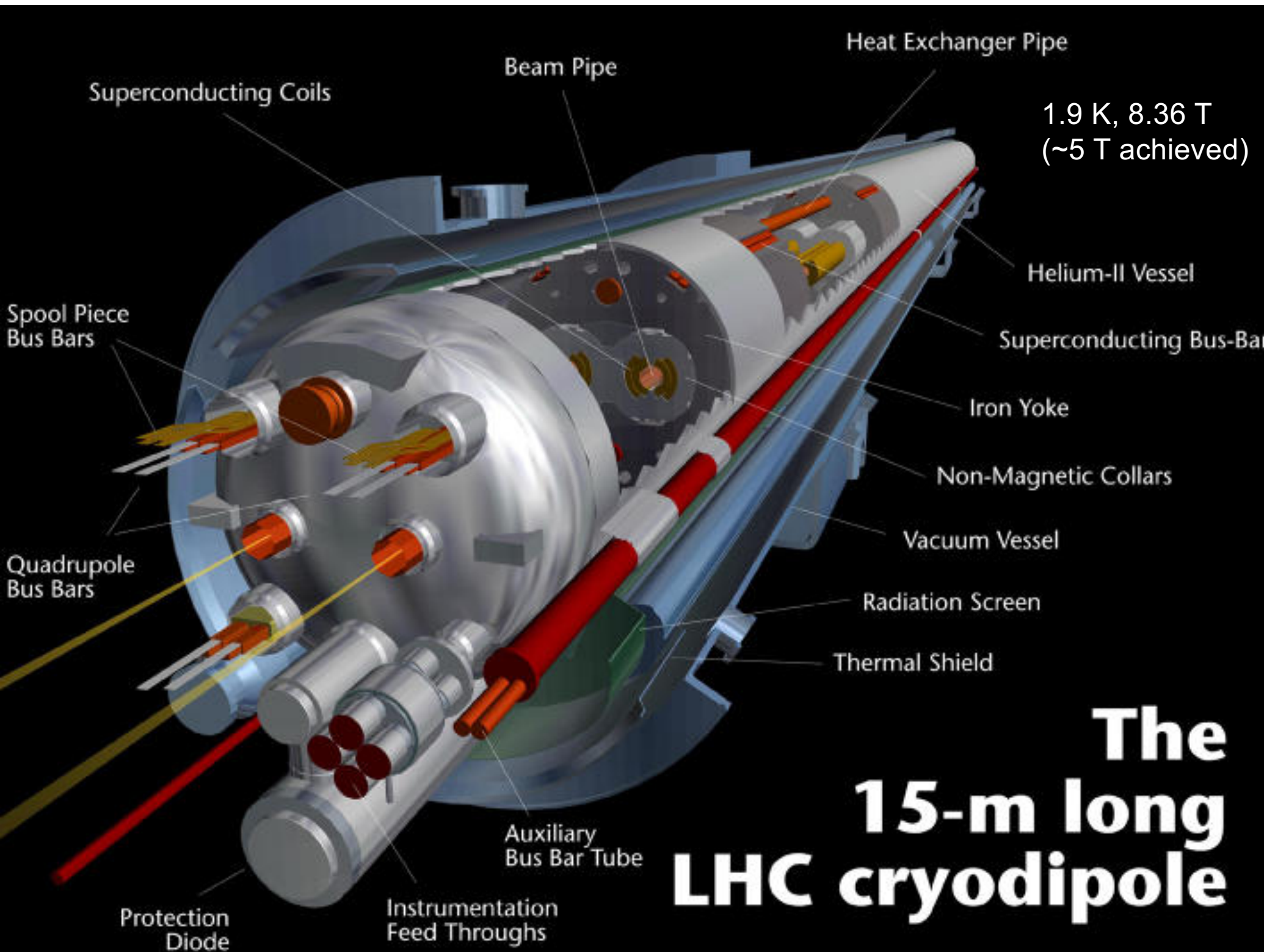

Superconducting Magnet Transfer Function

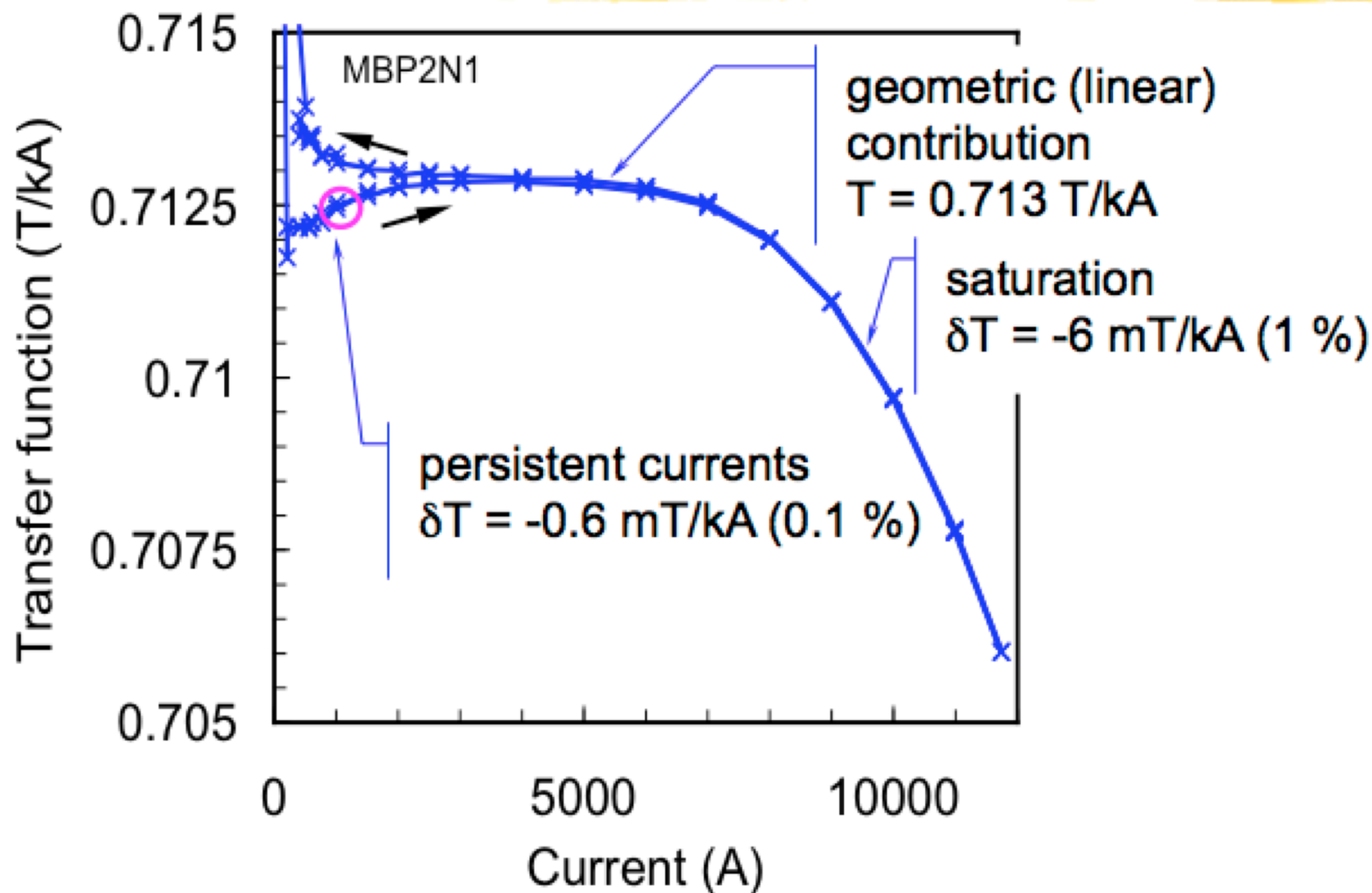

- Transfer function: relationship between current/field
 - Persistent currents: surface currents during magnet ramping

Quenching

- Magnetic stored energy

$$E = \frac{B^2}{2\mu_0}$$

$$B = 5 \text{ T}, \quad E = 10^7 \text{ J/m}^3$$

- LHC dipole

$$E = \frac{LI^2}{2} \quad L = 0.12 \text{ H} \quad I = 11.5 \text{ kA}$$

$$\Rightarrow E = 7.8 \times 10^6 \text{ J}$$

22 ton magnet

\Rightarrow Energy of 22 tons, $v = 92 \text{ km/hr!}$



*the most likely
cause of **death**
for a
superconducting
magnet*

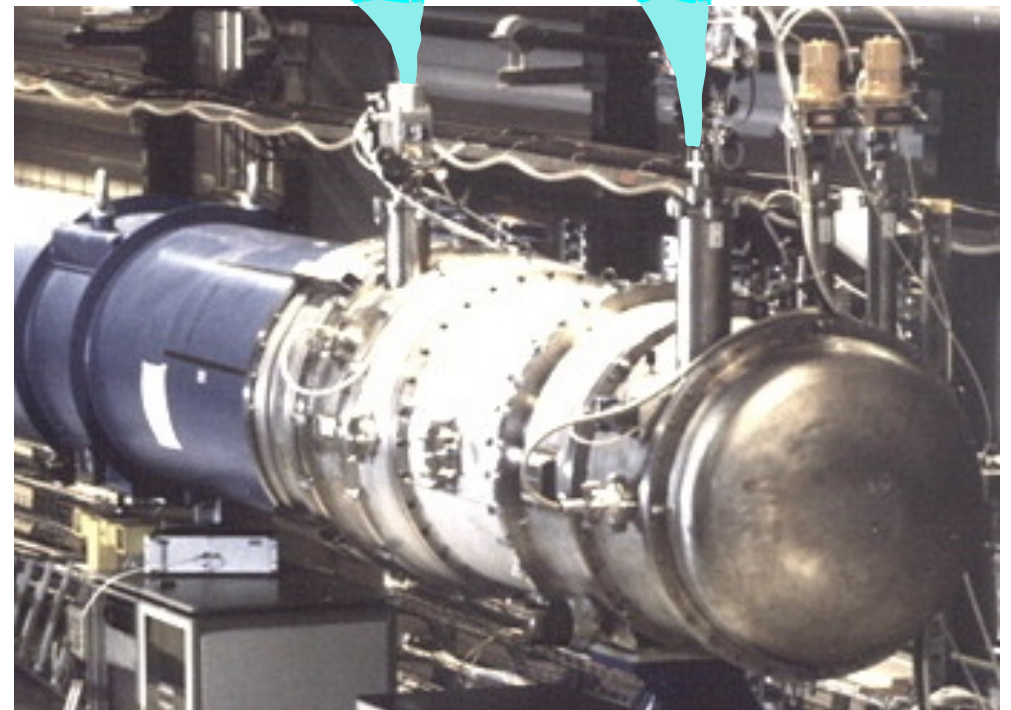

Quench Process

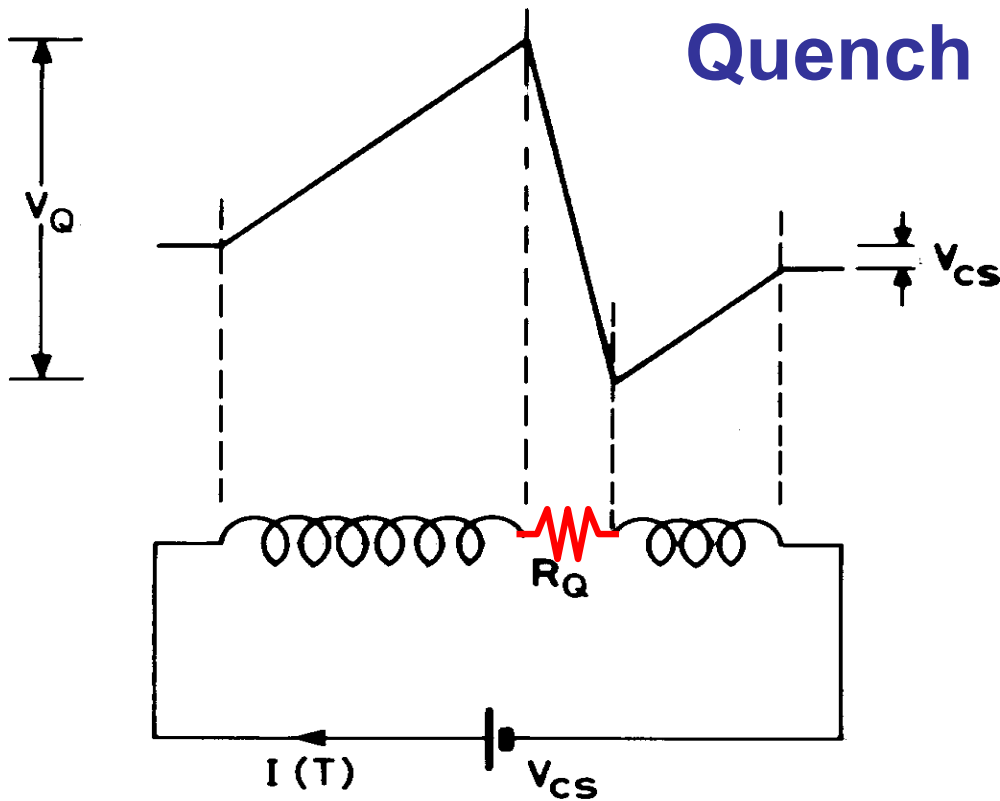

- Resistive region starts somewhere in the winding at a point: A problem!
 - Cable/insulation slipping
 - Inter-cable short; insulation failure
- Grows by thermal conduction
- Stored energy $\frac{1}{2}LI^2$ of the magnet is dissipated as heat
- Greatest integrated heat dissipation is at localized point where the quench starts
- Internal voltages **much** greater than terminal voltage ($= V_{CS}$ current supply)
 - Can profoundly damage magnet
 - Quench protection is important!

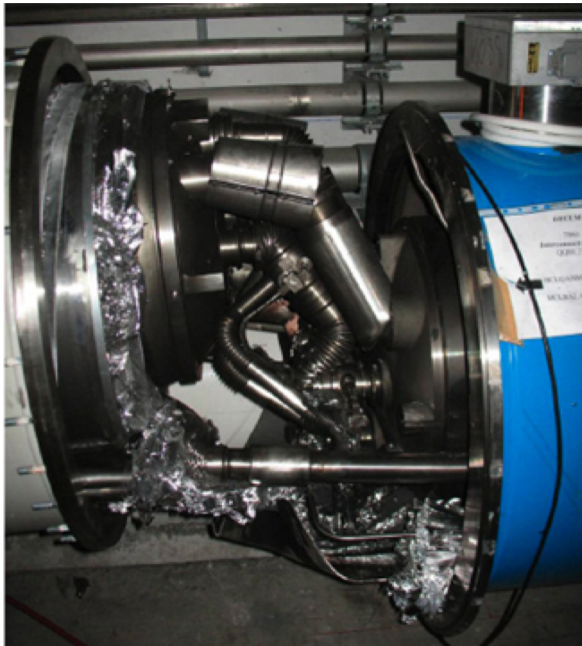

Quench Training

- Intentionally raising current until magnet quenches
 - Later quenches presumably occur at higher currents
 - Compacts conductors in cables, settles in stable position
 - Sometimes necessary to achieve operating current

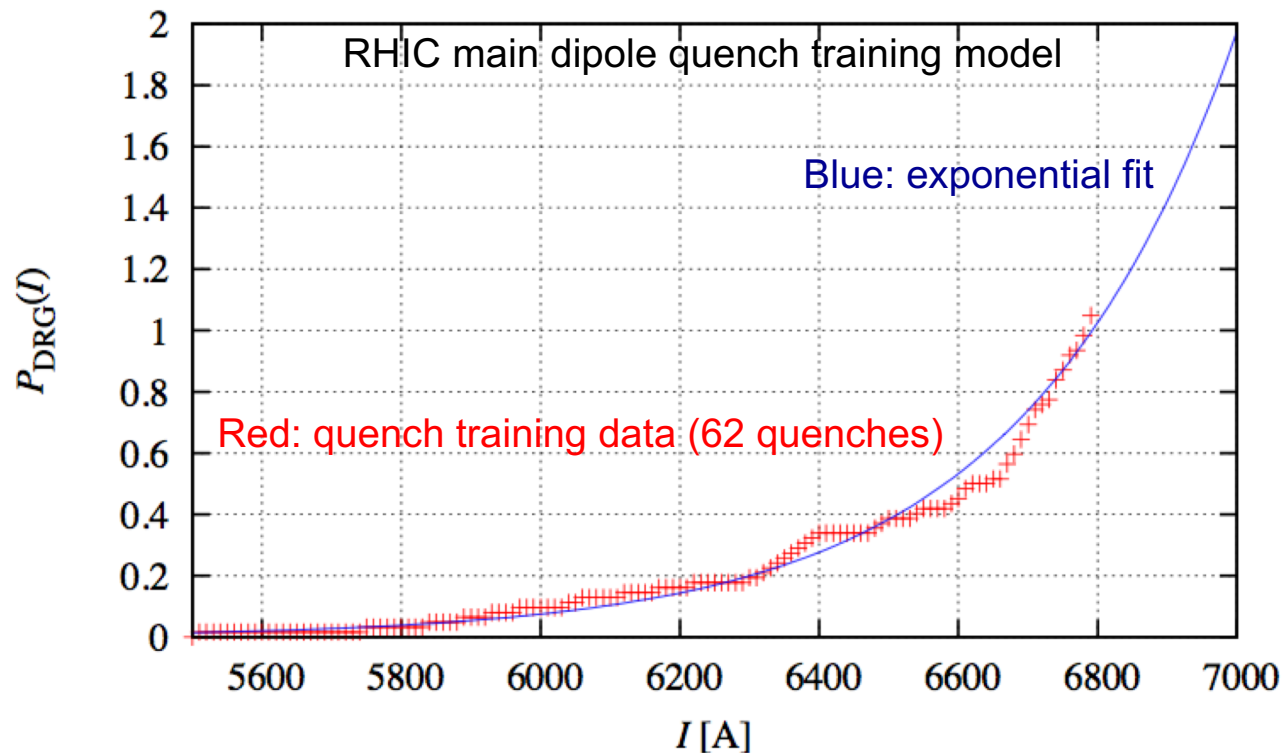

“Energy Upgrade as Regards Quench Performance”, W.W. MacKay and S. Tepikian

Direct-Wind Superconducting Magnets (BNL)

- 6T Iron-free (superconducting)
- Solid state coolers (no Helium)
- Field containment (LC magnet)
- “Direct-wind” construction

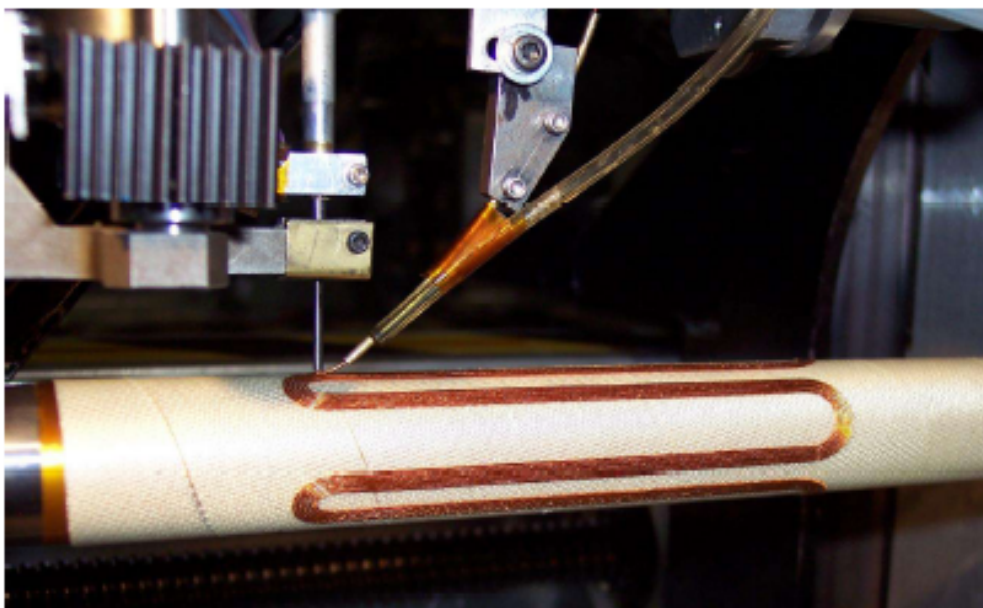

World's first “direct wind” coil machine at BNL

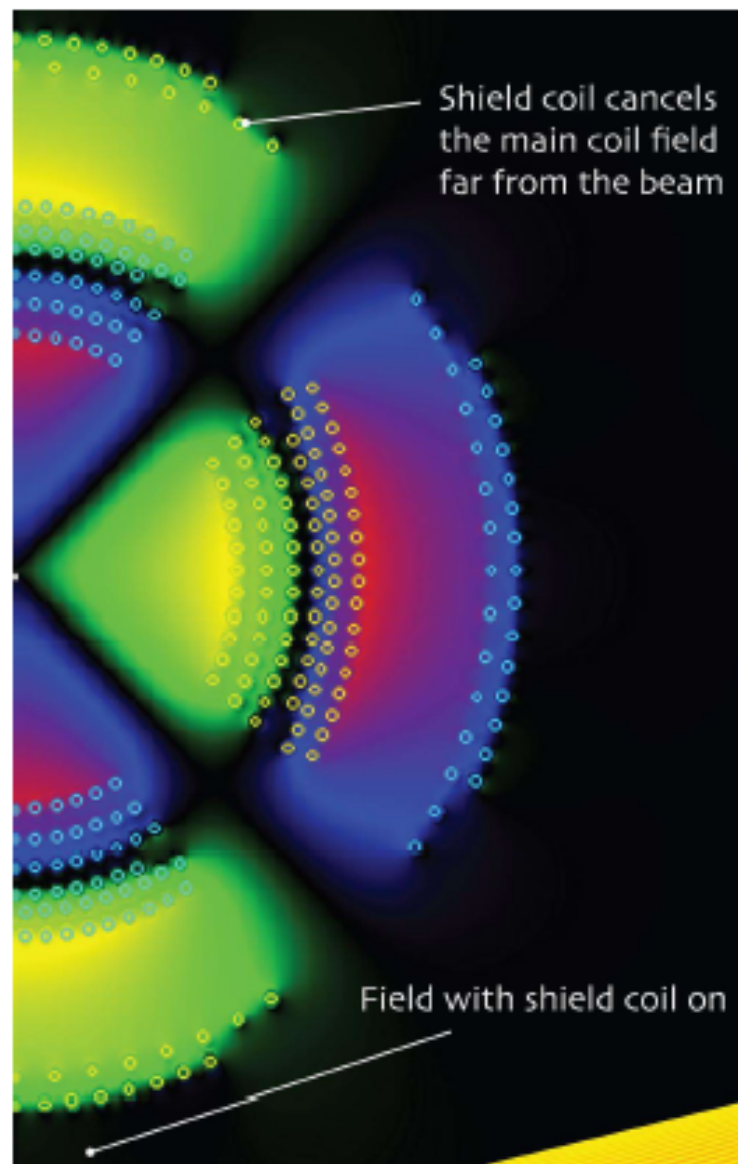

Linear Collider magnet

FELs: Wigglers and Undulators

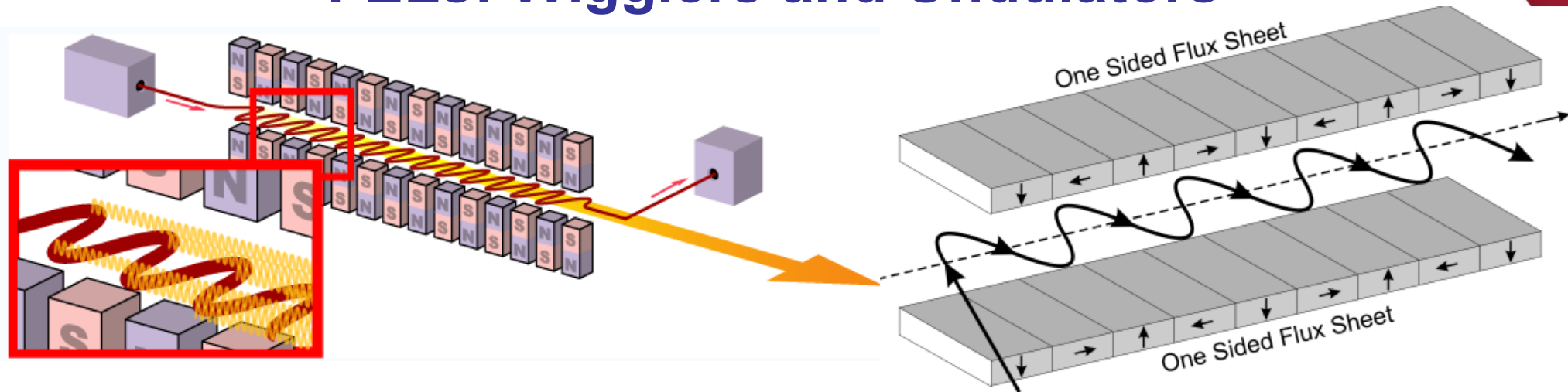

- Used to produce synchrotron radiation for FELs
 - Often rare earth permanent magnets in Halbach arrays
 - Adjust magnetic field intensity by moving array up/down
 - **Undulators:** produce nm wavelength FEL light from ~cm magnetic periods (γ^2 leverage in undulator equation)
 - Narrow band high spectral intensity
 - **Wigglers:** higher energy, lower flux, more like dipole synchrotron radiation
 - More about synchrotron light and FELs etc next week
 - LCLS: 130+m long undulator!

Feedback to Magnet Builders

http://www.agsrhichome.bnl.gov/AP/ap_notes/RHIC_AP_80.pdf

FEEDBACK BETWEEN ACCELERATOR PHYSICISTS AND MAGNET BUILDERS

S. PEGGS

*Relativistic Heavy Ion Collider, Brookhaven National Laboratory,
Upton, New York 11973, USA*

Submitted to the proceedings of the LHC Single Particle Dynamics Workshop, Montreux, 1996.

1 PHILOSOPHY

Our task is not to record history but to change it. *K. Marx (paraphrased)*

How should Accelerator Physicists set magnet error specifications? In a crude social model, they place tolerance limits on undesirable nonlinearities and errors (higher order harmonics, component alignments, et cetera). The Magnet Division then goes away for a suitably lengthy period of time, and comes back with a working magnet prototype that is reproduced in industry.